

iCOM

**SERVICE
MANUAL**

VHF MARINE TRANSCEIVER

IC-M87

INTRODUCTION

This service manual describes the latest service information for the **IC-M87** VHF MARINE TRANSCEIVER at the time of publication.

Model	Version	Symbol	AC adapter	Power
IC-M87	Europe	EUR	BC-147E	5 W
	U. K.	UK	—	5 W
	Germany	FRG	BC-147E	1 W

To upgrade quality, all electrical or mechanical parts and internal circuits are subject to change without notice or obligation.

DANGER

NEVER connect the transceiver to an AC outlet or to a DC power supply that uses more than 8.3 V. This will ruin the transceiver.

DO NOT expose the transceiver to rain, snow or any liquids.

DO NOT reverse the polarities of the power supply when connecting the transceiver.

DO NOT apply an RF signal of more than 20 dBm (100 mW) to the antenna connector. This could damage the transceiver's front end.

ORDERING PARTS

Be sure to include the following four points when ordering replacement parts:

1. 10-digit order numbers
2. Component part number and name
3. Equipment model name and unit name
4. Quantity required

<SAMPLE ORDER>

1110002750 S.IC TA7S01F IC-M87 MAIN UNIT 1 piece
8210019100 2600 Front panel IC-M87 CHASSIS 5 pieces

Addresses are provided on the inside back cover for your convenience.



REPAIR NOTES

1. Make sure a problem is internal before disassembling the transceiver.
2. **DO NOT** open the transceiver until the transceiver is disconnected from its power source.
3. **DO NOT** force any of the variable components. Turn them slowly and smoothly.
4. **DO NOT** short any circuits or electronic parts. An insulated tuning tool **MUST** be used for all adjustments.
5. **DO NOT** keep power ON for a long time when the transceiver is defective.
6. **DO NOT** transmit power into a signal generator or a sweep generator.
7. **ALWAYS** connect a 40 dB or 50 dB attenuator between the transceiver and a deviation meter or spectrum analyser when using such test equipment.
8. **READ** the instructions of test equipment thoroughly before connecting equipment to the transceiver.

TABLE OF CONTENTS

SECTION 1	SPECIFICATIONS	
SECTION 2	INSIDE VIEWS	
SECTION 3	DISASSEMBLY INSTRUCTIONS	
SECTION 4	CIRCUIT DESCRIPTION	
4 - 1	RECEIVER CIRCUITS	4 - 1
4 - 2	TRANSMITTER CIRCUITS	4 - 2
4 - 3	PLL CIRCUITS	4 - 3
4 - 4	POWER SUPPLY CIRCUITS	4 - 3
4 - 5	CPU PORT ALLOCATIONS	4 - 4
SECTION 5	ADJUSTMENT PROCEDURES	
5 - 1	PREPARATION	5 - 1
5 - 3	SOFTWARE ADJUSTMENT	5 - 6
SECTION 6	PARTS LIST	
SECTION 7	MECHANICAL PARTS AND DISASSEMBLY	
SECTION 8	SEMI-CONDUCTOR INFORMATION	
SECTION 9	BOARD LAYOUTS	
9 - 1	CHARGER UNIT	9 - 1
9 - 2	VR UNIT	9 - 1
9 - 3	CONNECTOR UNIT	9 - 1
9 - 4	MAIN UNIT.....	9 - 2
9 - 5	LOGIC UNIT	9 - 4
SECTION 10	BLOCK DIAGRAM	
SECTION 11	VOLTAGE DIAGRAM	

SECTION 1 SPECIFICATIONS

■ GENERAL

- Frequency coverage : TX: 156.000 MHz–161.450 MHz, RX: 156.000 MHz–163.450 MHz [MARINE]
TX/RX: 146.000 MHz–174.000 MHz [PMR]
- Number of free channels : 22 channels
- Type of emission : 16K0G3E (Wide; 25 kHz) [MARINE] for ATIS
16K0F3E (Wide, 25 kHz), 8K50F3E (Narrow, 12.5 kHz) [PMR]*1
14K0F3E (Wide, 20 kHz), 8K50F3E (Narrow, 12.5 kHz) [PMR]*2
- Antenna impedance : Type SMA / 50 Ω
- Power supply requirement : BP-227 (7.2 V DC, negative ground)
- Current drain (approx.) : Transmit at High (5.0 W or 1.0 W) 1.6 A [5.0 W type], 0.7 A [1.0 W type]
at Middle (3.0 W) 1.2 A [5.0 W type] only
at Low (1.0 W or 0.5 W) 0.7 A [5.0 W type], 0.6 A [1.0 W type]
Receive at maximum audio 200 mA
at stand-by 20 mA
- Frequency stability : ±1.5 kHz
- Usable temperature range : –15°C to +55°C [MARINE]; –25°C to +55°C [PMR]
- Dimensions (projections not included) : 62(W) × 97(H) × 39(D) mm; 2 7/16(W) × 3 13/16(H) × 1 17/32(D) in.
- Weight (with antenna, BP-227) : 280 g; 9.88 oz; 0.62 lb

■ TRANSMITTER

- RF output power (with BP-227) : 5 W type: 5 W / 3 W / 1 W (High / Middle/ Low) [MARINE]*1, [PMR]
1 W type: 1 W / 0.5 W (High / Low) [MARINE]*2
- Modulation system : Variable reactance frequency modulation
- Maximum frequency deviation : ±5.0 kHz (Wide; 25 kHz) [MARINE]
±5.0 kHz (Wide; 25 kHz), ±2.5 kHz (Narrow; 12.5 kHz) [PMR]*1
±4.0 kHz (Wide; 20 kHz), ±2.5 kHz (Narrow; 12.5 kHz) [PMR]*2
- Spurious emissions : 0.25 μW < 2 GHz, 1.0 μW > 2 GHz
- Adjacent channel power : 70 dB [MARINE], 70 dB (Wide; 25 kHz) [PMR], 60 dB (Narrow; 12.5 kHz) [PMR]
- Residual modulation : 40 dB [MARINE], 40 dB (Wide) [PMR], 34 dB (Narrow) [PMR]
- Audio harmonic distortion : Less than 10 % at 60% deviation
- FM Hum and noise : 40 dB [MARINE], 40 dB (Wide; 25 kHz) [PMR], 34 dB (Narrow; 12.5 kHz) [PMR]
- Audio frequency response : +1 dB to –3 dB of 6 dB octave from 300 Hz to 3000 Hz [MARINE] only
- Limiting charact modulation : 60 % – 100 % of maximum deviation
- Ext. microphone connector : 9-pin multi conductor/2.2 kΩ

■ RECEIVER

- Receive system : Double conversion superheterodyne system
- Intermediate frequencies : 1st 31.05 MHz
2nd 450 kHz
- Sensitivity : –2 dBμ [MARINE] (–4 dBμ[PMR]) emf typical at 20 dB SINAD
- Squelch sensitivity : +0 dBμ emf typical
- Adjacent channel selectivity : 70 dB [MARINE], 70 dB (Wide) [PMR], 60 dB (Narrow) [PMR]
- Spurious response rejection : 70 dB
- Intermodulation rejection ratio : 68 dB [MARINE], 65 dB [PMR]
- Hum and noise : 40 dB [MARINE], 40 dB (Wide) [PMR], 34 dB (Narrow) [PMR]
- Audio output power (at 7.5 V DC) : 200 mW [MARINE] (350 mW [PMR] typical) at 10% distortion with an 8 Ω load
- Audio frequency response : +1 dB to –3 dB of –6 dB octave from 300 Hz to 3000 Hz [MARINE] only
- Ext. speaker connector : 9-pin multi connector/8 Ω

Specifications are measured in accordance with EN301-178-2/EN300-086.

All stated specifications are subject to change without notice or obligation.

NOTE: *[EUR], [UK] only, *[FRG] only

■ VHF MARINE CHANNEL LIST

Channel No.		Frequency (MHz)		Channel No.		Frequency (MHz)		Channel No.		Frequency (MHz)	
USA	INT	Transmit	Receive	USA	INT	Transmit	Receive	USA	INT	Transmit	Receive
	01	156.050	160.650		22	157.100	161.700	74	74	156.725	156.725
01A		156.050	156.050	22A		157.100	157.100		75*1	156.775	156.775
	02	156.100	160.700		23	157.150	161.750		76*1	156.825	156.825
	03	156.150	160.750	23A		157.150	157.150	77*1	77	156.875	156.875
03A		156.150	156.150	24	24	157.200	161.800		78	156.925	161.525
	04	156.200	160.800	25	25	157.250	161.850	78A		156.925	156.925
	05	156.250	160.850	26	26	157.300	161.900		79	156.975	161.575
05A		156.250	156.250	27	27	157.350	161.950	79A		156.975	156.975
06	06	156.300	156.300	28	28	157.400	162.000		80	157.025	161.625
	07	156.350	160.950	37A		157.850	157.850	80A		157.025	157.025
07A		156.350	156.350		60	156.025	160.625		81	157.075	161.675
08	08	156.400	156.400		61	156.075	160.675	81A		157.075	157.075
09	09	156.450	156.450	61A		156.075	156.075		82	157.125	161.725
10	10	156.500	156.500		62	156.125	160.725	82A		157.125	157.125
11	11	156.550	156.550		63	156.175	160.775		83	157.175	161.775
12	12	156.600	156.600	63A		156.175	156.175	83A		157.175	157.175
13*1	13	156.650	156.650		64	156.225	160.825	84	84	157.225	161.825
14	14	156.700	156.700	64A		156.225	156.225	84A		157.225	157.225
15*1	15*1	156.750	156.750		65	156.275	160.875	85	85	157.275	161.875
16	16	156.800	156.800	65A		156.275	156.275	85A		157.275	157.275
17*1	17*1	156.850	156.850		66	156.325	160.925	86	86	157.325	161.925
	18	156.900	161.500	66A		156.325	156.325	86A		157.325	157.325
18A		156.900	156.900	67*1	67	156.375	156.375	87		157.375	161.975
	19	156.950	161.550	68	68	156.425	156.425	87A	87	157.375	157.375
19A		156.950	156.950	69	69	156.475	156.475	88		157.425	162.025
20	20	157.000	161.600	70*2	70*2	156.525	156.525	88A	88	157.425	157.425
20A		157.000	157.000	71	71	156.575	156.575				
	21	157.050	161.650	72	72	156.625	156.625				
21A		157.050	157.050	73	73	156.675	156.675				

*1 Low power only, *2 Receive only

NOTE: USA channels for U.K. version only.

SECTION 2 INSIDE VIEWS

• LOGIC UNIT

Bottom view

*: Located under side of this point.

IN/EXT microphone switch
(Q461, Q462: UN911H)

Microphone amplifier
(IC471: NJM2904V)

AF mute
(IC481: TC4W66FU)

S5V regulator
(Q561: 2SA1588)

M5V regulator
(Q551: 2SB1132
Q552: XP6501
Q553: DTC144EU)

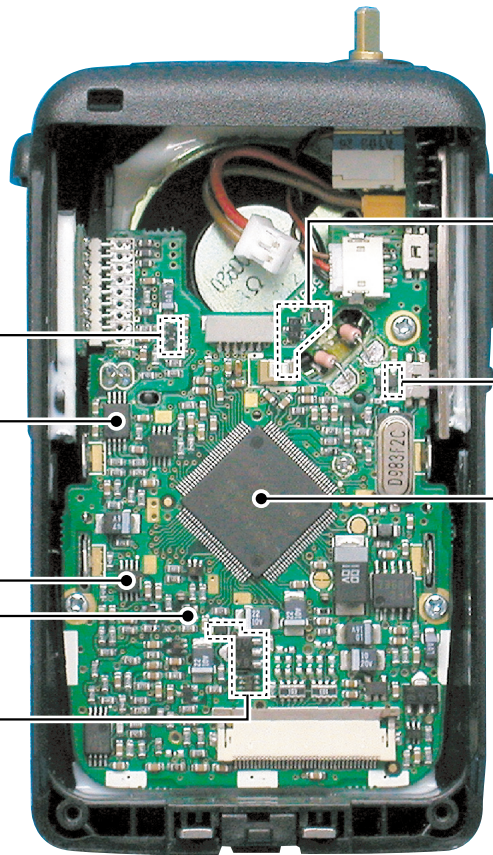

AF mute circuit
(Q441*: 2SC4116
Q442*: CPH3403
Q443 : CPH3403
Q444 : DTC144EU)

EEPROM
(IC591*: HN58X2416TI)

CPU
(IC661: μPC780316GC-511-9EB)

• MAIN UNIT

Top view

Antenna switching circuit
(D131, D151: 1SV307)
D152: MA77

RF amplifier
(Q165: 3SK294)

Power amplifier
(Q111: RD07MVS1)

Pre-drive amplifier
(Q101: RD01MUS1)

T5V regulator
(Q323: 2SA1588)

R5V regulator
(Q322: 2SA1588)

V5V regulator
(Q321: 2SA1588)

VCO circuit

1st Mixer
(Q191: 3SK299)

AF mute
(IC281: TC4W66FU)

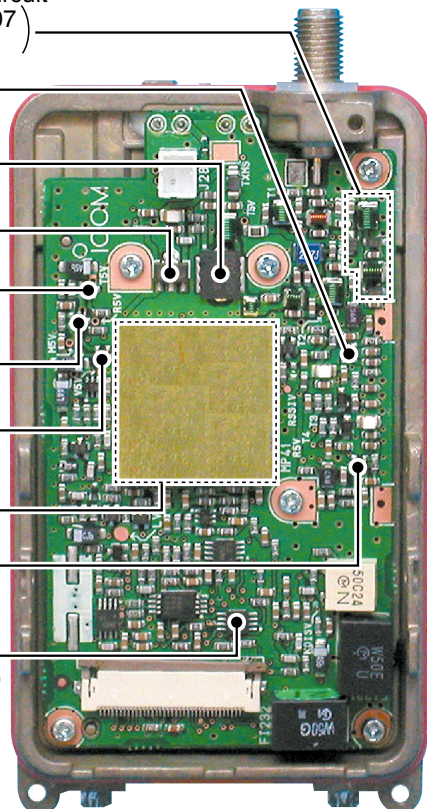

Bottom view

APC control
(IC141: TA75S01F)

Bandpass filter
(FI211: FL-355)

PLL IC
(IC1: MB15A02PFV)

Reference frequency
crystal
(X1: CR664A;
15.300 MHz)

IF DET IC
(IC231:
TA31136FN)

IF amplifier
(Q211: 2SC4215)

D/A converter
(IC251:
M62363FP-650C)

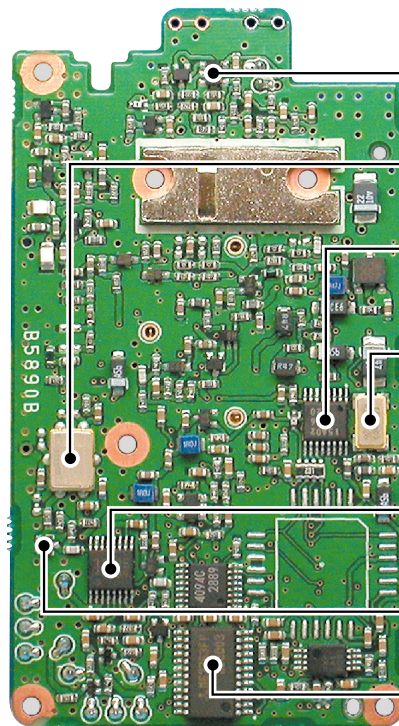

SECTION 3 DISASSEMBLY INSTRUCTIONS

1. Removing the chassis panel

- ① Remove a nut (A).
- ② Unscrew 2 screws (B) (2 × 8 mm, black) and 3 screws (C) (2 × 4 mm, black) from the chassis.
- ③ Take off the chassis in the direction of the arrow.

NOTE: * Tighten the screws in order of a number (1-6) when assembling.

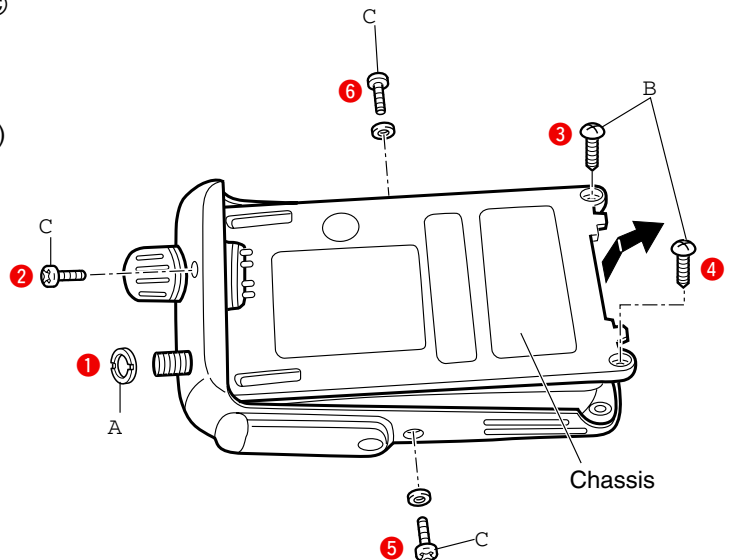

2. Removing the LOGIC unit.

- ① Unplug the cable from J281 on the MAIN unit to separate the LOGIC unit
- ② Separate the front panel from the chassis in the direction of the arrow.
- ③ Unsolder the leads of speaker (2 points) and connector unit (9 points).
- ④ Unscrew 3 screws (D) (2 × 4 mm, silver) to separate the front panel.

NOTE: * Tighten the screws in order of a number (1-3) when assembling.

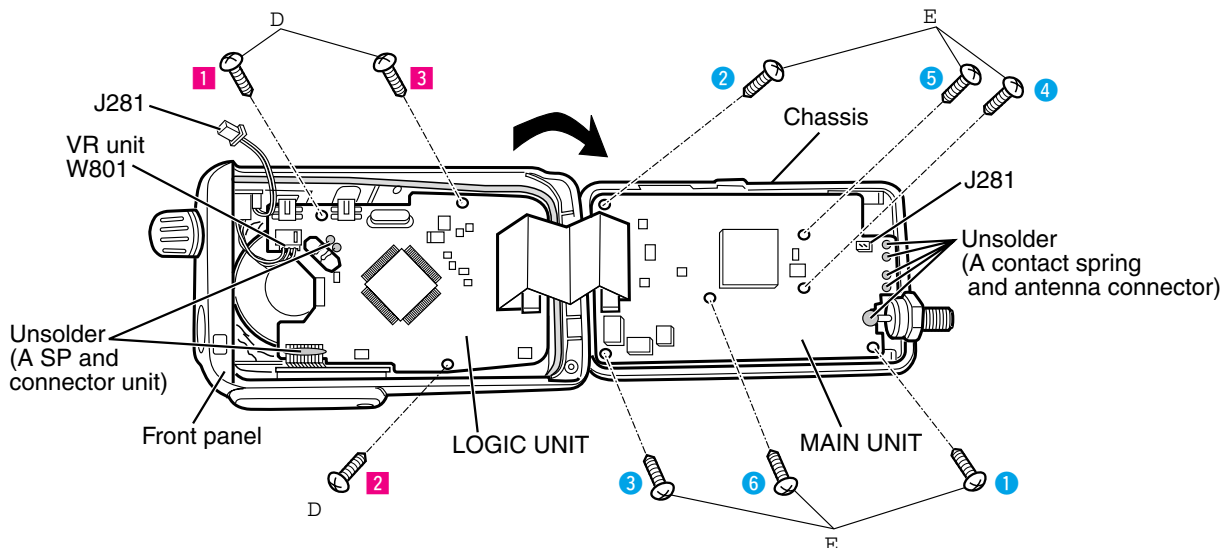

3. Removing the MAIN unit

- ① Unsolder the leads of contact spring (4 points) and antenna connector (1 point).
- ② Unscrew 6 screws (E) (2 × 4 mm, silver) to separate the chassis.

NOTE: * Tighten the screws in order of a number (1-6) when assembling.

SECTION 4 CIRCUIT DESCRIPTION

4-1 RECEIVER CIRCUITS

4-1-1 ANTENNA SWITCHING CIRCUIT (MAIN UNIT)

The antenna switching circuit functions as a low-pass filter while receiving and as resonator circuit while transmitting. The circuit does not allow transmit signals to enter receiver circuits.

Received signals from the antenna connector pass through the low-pass filter (L131, L132, C131–C136) and antenna switching circuit (D151, D152). The filtered signals are then applied to the RF amplifier circuit (Q165).

4-1-2 RF AND 1ST MIXER CIRCUITS (MAIN UNIT)

The 1st mixer circuit converts the received signals to a fixed frequency of the 1st IF signal with a PLL output frequency. By changing the PLL frequency, only the desired frequency will be passed through a pair of crystal filters at the next stage of the 1st mixer.

The signals from the antenna switching circuit are passed through the 2-stage bandpass filters (D154, D155, L154, L155) and amplified at the RF amplifier (Q165). The amplified signals are passed through another 2-stage bandpass filters (D181, D182, L181, L182), and then applied to the 1st mixer circuit (Q199).

The filtered signals are mixed at the 1st mixer (Q199) with a 1st LO signal coming from the PLL circuit to produce a 31.05 MHz 1st IF signal. The 1st IF signal is passed through a pair of crystal filter (F1211) and is then amplified at the IF amplifier (Q211).

4-1-3 2ND IF AND DEMODULATOR CIRCUITS (MAIN UNIT)

The 2nd mixer circuit converts the 1st IF signal to a 2nd IF signal. A double conversion superheterodyne system (which converts receive signal twice) improves the image rejection and obtain stable receiver gain.

The 1st IF signal is applied to a 2nd mixer section of the FM IF IC (IC231, pin 16). The signal is then mixed with a 2nd LO signal for conversion into a 450 kHz 2nd IF signal.

IC231 contains the 2nd mixer, limiter amplifier, quadrature detector and active filter circuits. A 30.6 MHz 2nd LO signal is produced at the PLL circuit using the reference frequency.

The 2nd IF signal from the 2nd mixer (IC231, pin 3) passes through ceramic filters (F1231, F1232) to remove unwanted heterodyned frequencies. It is then amplified at the limiter amplifier section (IC231, pin 5) and applied to the quadrature detector section (IC231, pins 10 and 11) to demodulate the 2nd IF signal into AF signals.

4-1-4 AF CIRCUIT (MAIN AND LOGIC UNITS)

AF signals from the FM IF IC (IC231, pin 9) are fed to the analog switch (IC282).

The AF signals (detected signals) passes through the AF mute switch (IC281A, pins 2 and 1) via "DET" signal, and are then applied to the analog switch (IC282, pin 1). The signals are then applied to the low-pass filter (IC261B, C266, C267, R270–R272).

The filtered AF signals are applied to and adjusted audio level at the [VOL] control (VR unit; R801) via the "VOLIN" signal. The level controlled signals are passed through the AF mute switch (LOGIC unit; Q411) which is controlled by "AFMS" signal from the CPU (IC661, pin 84). The passed signals are applied to the AF power amplifier (IC421, pin 4), and then output to the internal speaker or [EXT SP] jack after being passed through the de-emphasis circuit (R411, C413) to obtain the –6 dB/octave frequency characteristics

• 2ND IF AND DEMODULATOR CIRCUITS

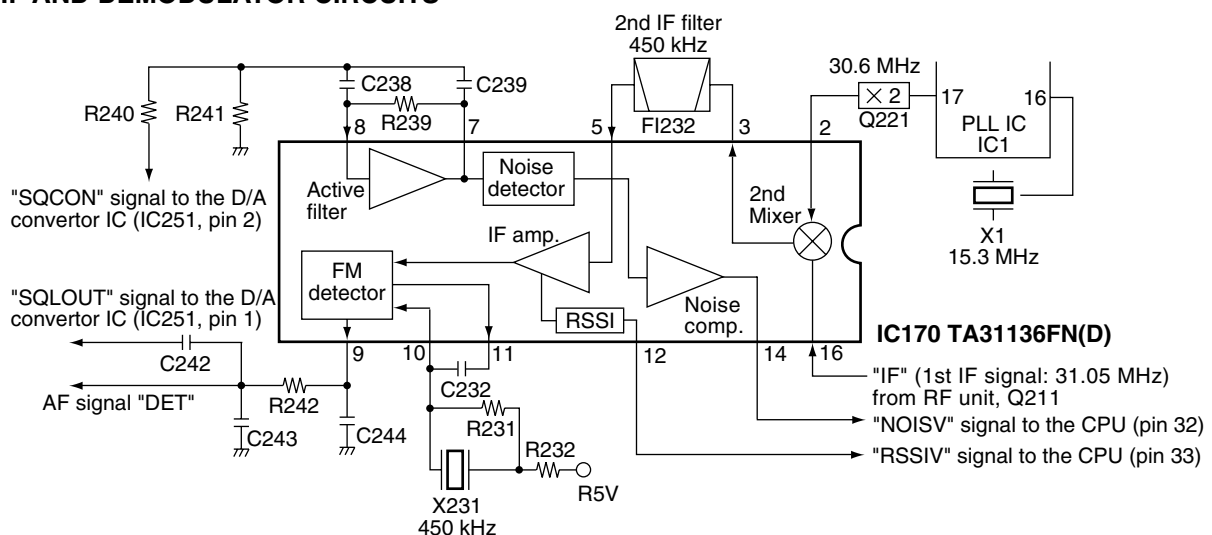

4-1-5 SQUELCH CIRCUIT (MAIN AND LOGIC UNITS)

The noise squelch circuit cuts out AF signals when no RF signals are received. By detecting noise components in the AF signals, the squelch circuit switches the AF mute switch.

A portion of the AF signals divided by C242 from the FM IF IC (IC231, pin 9) are applied to the D/A converter (IC251, pin 2) to adjust amplitude. The signals from the D/A converter (IC251, pin 1) are applied to the active filter section (IC231, pin 8, R239–R241, C237, C238). The active filter section amplifies and filters noise components. The filtered signals are applied to the noise detector section and output from IC231 (pin 14) as the “NOISV” signal.

The “NOISV” signal from IC231 (pin 14) is applied to the CPU (LOGIC unit; IC611, pin 32). The CPU compares the set squelch level voltage and “NOISV” signal voltage to control the squelch output.

4-2 TRANSMITTER CIRCUITS

4-2-1 MICROPHONE AMPLIFIER CIRCUIT (LOGIC AND MAIN UNITS)

The microphone amplifier circuit amplifies audio signals with +6 dB/octave pre-emphasis characteristics from the microphone to a level needed for the modulation circuit.

- **In case of the internal microphone**

The AF signals from the internal microphone (MC461) is applied to the microphone amplifier (IC471a, pin 6) via the “INMIC” signal.

- **In case of external microphone**

The AF signals from the external microphone (CP458) is applied to the microphone amplifier (IC471a, pin 6) via the “EXTMIC” signal.

The amplified signals are passed through the pre-emphasis circuit (R463, C463) and are then applied to the AF mute switch (IC481a, pin 1) via the “MICO” signal after being passed through the another microphone amplifier (IC471b, pins 2 and 1).

The AF signals are amplified again at the limiter-amplifier (IC491a, pin 2) and then passed through the low-pass filter (IC491b, pins 6 and 7). The filtered audio passes through the analog switch (MAIN unit; IC251, pins 4 and 3), and is then applied to the MAIN unit as the “MOCON” signal.

- **APC CIRCUIT**

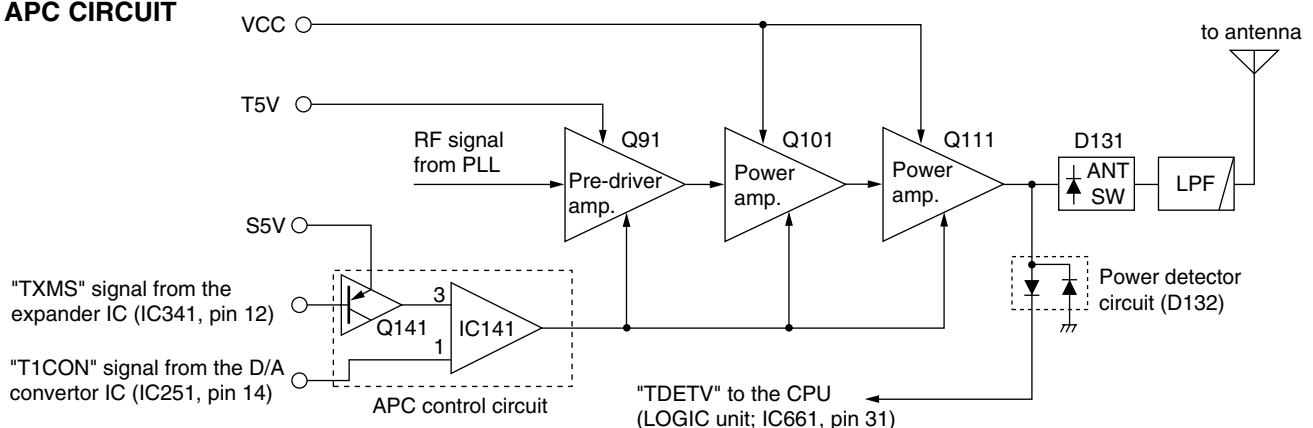

4-2-2 MODULATION CIRCUIT (MAIN UNIT)

The modulation circuit modulates the VCO oscillating signal (RF signal) using the microphone audio signals.

The audio signals “MOCON” change the reactance of D39 to modulate an oscillated signal at the TX VCO circuit (Q51, D35–D38, L34, L51, C32, C33, C52–C54). The oscillated signal is amplified at the buffer-amplifiers (Q61, Q62).

4-2-3 PRE-DRIVE/POWER AMPLIFIER CIRCUITS (MAIN UNIT)

The signal from the VCO circuit passes through the transmit/receive switching circuit (D91, D92) and is applied to the buffer-amplifier (Q91). The amplified signal is amplified by the pre-driver (Q101) and the power amplifier (Q101) to obtain 5 W of RF power (at 7.2 V). The amplified signal passes through the antenna switching circuit (D131), and low-pass filter (L131, L132, C131–C136) and is then applied to the antenna connector.

The bias current of the buffer amplifier (Q91), pre-driver (Q101) and power amplifier (Q111) is controlled by the APC circuit to stabilize the output power.

4-2-4 APC CIRCUIT (MAIN UNIT)

The APC circuit provides stable output power from the power amplifier even when the input voltage or temperature changes, and, selects HIGH, MIDDLE, LOW or EXTRA LOW output power. The APC circuit consists of a power detector and APC control circuits.

- **POWER DETECTOR CIRCUIT (MAIN UNIT)**

The power detector circuit (D132) detects the transmit output power level and converts it to DC voltage as the “TDETV” signal. The detected signal is applied to the APC control circuit.

- **APC CONTROL CIRCUIT (MAIN AND LOGIC UNITS)**

The “TDETV” signal from the power detector circuit is applied to the CPU (LOGIC unit; IC661, pin 31) to control the input voltage of the buffer amplifier (Q91), pre-driver (Q101) and power amplifier (Q111). When the output power changes, the CPU (LOGIC unit; IC661) outputs APC control signal to the D/A converter (IC190). And then “T1CON” signal from the D/A converter controls the APC controller (IC141) to provide stable output power.

4-3 PLL CIRCUIT (MAIN UNIT)

4-3-1 GENERAL

The PLL circuit provides stable oscillation of the transmit frequency and receive 1st LO frequency. The PLL output compares the phase of the divided VCO frequency to the reference frequency. The PLL output frequency is controlled by the divided ratio (N-data) of a programmable divider. IC1 is a PLL IC which controls both VCO circuit for TX and RX.

The PLL circuit, using a one chip PLL IC (IC1), directly generates the transmit frequency and receive 1st IF frequency with VCOs. The PLL sets the divided ratio based on serial data from the CPU on the LOGIC unit and compares the phases of VCO signals with the reference oscillator frequency. The PLL IC detects the out-of-step phase and output from the pin 6 for TX and RX. The reference frequency (15.3 MHz) is oscillated at X1.

4-3-2 TX AND RX LOOP CIRCUITS (MAIN UNIT)

The generated signal at the TX-VCO circuit (Q51, D35–D38, L34, L51, C32, C33, C52–C54) or RX-VCO (Q41, D31–D34, L32, L41, C31, C41–C43) enters the PLL IC (IC1, pin 8) and is divided at the programmable divider section and is then applied to the phase detector section.

The phase detector compares the input signal with a reference frequency, and then outputs the out-of-phase signal (pulse-type signal) from pin 6.

The pulse-type signal is converted into DC voltage (lock voltage) at the loop filter (R17–R19, C16–C19), and then applied to varactor diodes (TX; D35–D38, RX; D31–D34) of the TX-VCO and RX-VCO to stabilize the oscillated frequency.

4-3-3 TX AND RX VCO CIRCUITS (MAIN UNIT)

The VCO circuit from Q41 (RX) and Q5 (TX) are buffer amplified at the Q61 and Q62, and then sent to the TX/RX switch (D91, D92). The receive LO signal is applied to the 1st mixer circuit (Q191) through an attenuator (L203, R203–R206, C202, C203), and the transmit signal is applied to the buffer amplifier (Q91). A portion of the VCO output is reapplied to the PLL IC (IC1, pin 8) via the Q71.

4-4 POWER SUPPLY CIRCUITS VOLTAGE LINES

LINE	DESCRIPTION
HV	The voltage from the attached battery pack.
VCC	The same voltage as the HV line (battery voltage) which is controlled by the power switch (VR unit; [OFF/VOL] control). The output voltage is applied to the pre-drive (MAIN unit; Q101), power amplifier (MAIN unit; Q111), CPU5V and M5V regulator circuits (LOGIC unit; IC551 and Q551–Q553).
CPU5V	Common 5 V converted from the VCC line by the CPU5V regulator circuit (LOGIC unit; IC551). The output voltage is applied to the CPU (LOGIC unit; IC661), REG5V regulator, RESET circuit (LOGIC unit; IC581), etc.
M5V	Common 5V converted from the VCC line by the M5V regulator circuit (LOGIC unit; Q551–Q553). The output voltage is applied to R5V, T5V, V5V and S5V regulator circuits (LOGIC unit; Q322, Q323, Q321 and Q561).
R5V	Receive 5V converted from the M5V line by the R5V regulator circuit (MAIN unit; Q322). The regulated voltage is applied to the 1st mixer circuit (MAIN unit; Q191), RF and IF amplifiers (MAIN unit; Q165, Q211).
T5V	Transmit 5V converted from the M5V line by the T5V regulator circuit (MAIN unit; Q222). The regulated voltage is applied to the buffer amplifier (MAIN unit; Q91).
V5V	Common 5V converted from the M5V line by the V5V regulator circuit (MAIN unit; Q321). The regulated voltage is applied to the ripple filter circuit (Q47).
S5V	Common 5V converted from the M5V line by the S5V regulator circuit (LOGIC unit; Q561). The regulated voltage is applied to the microphone amplifier (LOGIC unit; IC471), limit amplifier (LOGIC unit; IC491), LCD back light (LOGIC unit; DS651–DS654), etc.

• PLL CIRCUIT

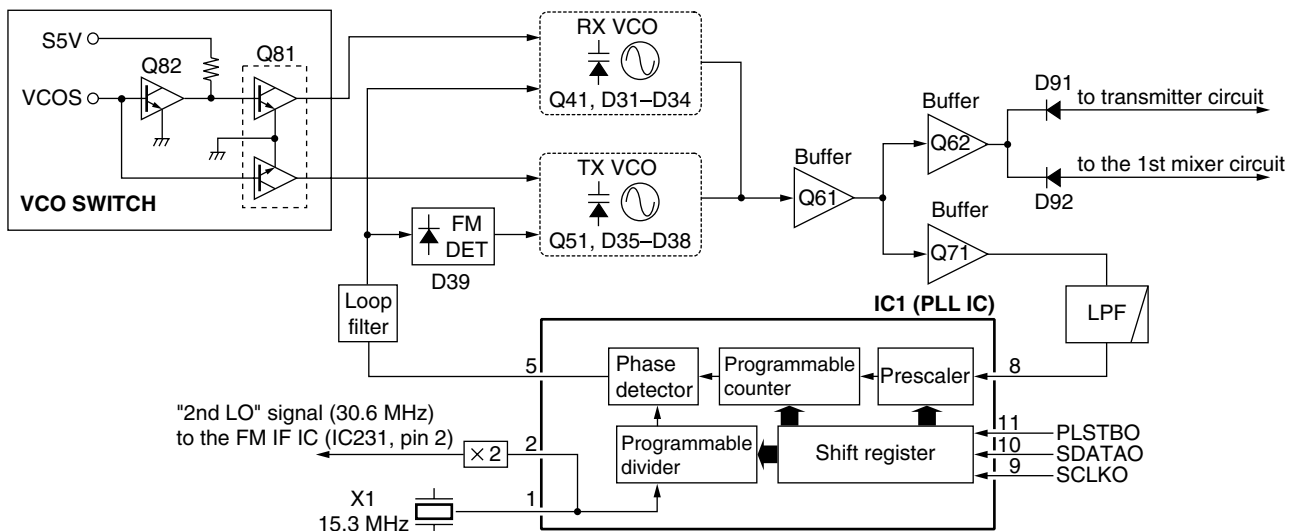

4-5 PORT ALLOCATIONS

4-5-1 CPU (LOGIC UNIT; IC661)

Pin number	Port name	Description
1	BEEP	Outputs beep audio signals.
2	VSSTB	Outputs strobe signals for the scrambler IC (MAIN unit; IC381, pin 10).
3	EXSTB	Outputs strobe signals for the expander IC (MAIN unit; IC341, pin 1).
4	DASTB	Outputs strobe signals for the D/A converter (MAIN unit; IC251, pin 6).
5	PLSTB	Outputs strobe signals for the PLL IC (MAIN unit; IC1, pin 11).
6	ERXDI	Input port for cloning signals.
7	ETXDO	Outputs cloning signals.
10	SDATA	Outputs serial data for PLL, scrambler ICs, etc.
11	SCLK	Outputs serial clock for PLL, scrambler ICs, etc.
12	ESCK	Outputs clock signal for the EEPROM (IC591, pin 6).
13	ESDA	I/O port for EEPROM data signal (IC591, pin 5).
17	CSIFT	Outputs CPU clock shift signal. High : While clock is shifted.
27	WDECV	Input port for the WX tone detection.
28	WETIN	Input port for the transceiver's internal inundation detection.
29	EXTSV	Input port for the external terminal connecting detection.
30	BATTV	Input port for the battery voltage detection.
31	TDETV	Input port for transmit RF level detection.
32	NOISV	Input port for noise level detection.
33	RSSIV	Input port for RSSI voltage level detection.
34	LOINV	Input port for VCO lock voltage level detection.
35	TEMPV	Input port for the transceiver's internal temperature detection.
36	CDECV	Input port for CTCSS/DTCS detection.
38	ATIS	Outputs ATIS wave form.
46-48	COM0-COM2	Output LCD common signals
51-70	SEG0-SEG19	Output LCD segment signals.
75 76	CONT1 CONT2	Output LCD contrast control signals.
77 78	LEDS1 LEDS2	Output LCD and key's back light dimmer control signal.

Pin number	Port name	Description
79	STXMS	Outputs scrambler mute signal for the AF mute circuit (IC481, pin 3). Low : While scrambler is muting.
80	MICMS	Outputs mic mute signal for the AF mute circuit (IC481, pin 7). Low : While the microphone is muting.
81	ISPMS	Outputs the internal speaker control signal. High : While the speaker is muting.
82	LDTFS	Outputs DTCS's low-pass filter cut-off frequency control signal.
83	W/NS	Outputs Wide/Narrow control signal. high : While Narrow is selected.
84	AFMS	Outputs the AF mute circuit control signal. High : The AF mute circuit is ON.
85	AFVS	Outputs AF amplifier's power supply control signal. High : The AF amplifier is ON.
86	M5VS	Outputs M5V power supply control signal. Low : The common 5V is supplied.
87	S5VS	Outputs S5V power supply control signal. Low : The common 5V is supplied.
88	V5VS	Outputs V5V power supply control signal. Low : The common 5V is supplied.
89	R5VS	Outputs R5V power supply control signal. Low : While receiving.
90	T5VS	Outputs T5V power supply control signal. Low : While transmitting.
98 99 100	CENC1 CENC2 CENC3	Output DTCS/CTCSS wave form.
102	PTTIN	Input port for [PTT] switch detection. High : While [PTT] switch is pushed.
103	EPTTIN	Input port for HM-138 (optional speaker-microphone)'s [PTT] switch detection. Low : While HM-138's [PTT] switch is pushed.
104	BTYPE	Input port for the connecting battery type detection. Low : While using alkaline cells.
109	SQL	Input port for the [SQL] key. Low : While [SQL] key is pushed.
110	UP	Input port for the [UP] key. Low : While [UP] key is pushed.

CPU–Continued

Pin number	Port name	Description
111	DOWN	Input port for the [DOWN] key. Low : While [DOWN] key is pushed.
112	CH/WX	Input port for the [CH/WX] key. Low : While [CH/WX] key is pushed.
113	16/9	Input port for the [16/9] key. Low : While [16/9] key is pushed.
114	SCAN	Input port for the [SCAN] key. Low : While [SCAN] key is pushed.
115	H/L	Input port for the [H/L] key. Low : While [H/L] key is pushed.
116	TDEC	Outputs decode monitor signal to CP641 on the LOGIC unit.
119	UNLK	Input port for the PLL unlock signal. High : PLL lock voltage is unlocked.

4-5-2 EXPANDER IC (MAIN UNIT; IC341)

Pin number	Port name	Description
5	SRXMS	Outputs the AF mute switch (IC281, pin 3) control signal. Low : While the scrambler decoding signal is muted.
6	DETMS	Outputs the AF mute switch (IC281, pin 7) control signal. Low : While AF signal is muted.
7	CKSIS	Outputs the scrambler IC's clock shift control signal. High : While the clock is shifted.
11	ATTS	Outputs the RF attenuator control signal. High : While attenuator is ON.
12	TXMS	Outputs the TX mute switch (Q141) control signal. Low : While TX is attenuated.
13	VCOS	Outputs the TX/RX VCO control signal.

4-5-3 D/A CONVERTOR IC (MAIN UNIT; IC251)

Pin number	Port name	Description
2	SQCON	Outputs squelch level control signal.
3	MOCON	Outputs modulation level control signal.
10	DTCON	Outputs DTCS modulation balance control signal.
11	FRCON	Outputs reference frequency level control signal.
14	T1CON	Outputs bandpass filter1 tuned and transmitting power control signals.
15	T2CON	Outputs bandpass filter2 tuned signal.
22	T3CON	Outputs bandpass filter3 tuned signal.
23	T4CON	Outputs bandpass filter4 tuned signal.

SECTION 5 ADJUSTMENT PROCEDURES

5-1 PREPARATION

When adjusting IC-M87, optional OPC-966 CLONING CABLE, RS-232C cable and optional CS-M88 adj ADJUSTMENT SOFTWARE are required.

EQUIPMENT	GRADE AND RANGE	EQUIPMENT	GRADE AND RANGE
DC power supply	Output voltage : 7.2 V DC Current capacity : 3 A or more	FM deviation meter	Frequency range : 30–300 MHz Measuring range : 0 to ±10 kHz
RF power meter (terminated type)	Measuring range : 0.1–10 W Frequency range : 100–300 MHz Impedance : 50 Ω SWR : Less than 1.2 : 1	Audio generator	Frequency range : 300–3000 Hz Measuring range : 1–500 mV
Frequency counter	Frequency range : 0.1–300 MHz Frequency accuracy : ±1 ppm or better Sensitivity : 100 mV or better	Standard signal generator (SSG)	Frequency range : 100–300 MHz Output level : 0.1 μV–32 mV (–127 to –17 dBm)
Digital multimeter	Input impedance : 10 MΩ/DC or better	Attenuator	Power attenuation : 40 dB or more Capacity : 10 W or more

■ SYSTEM REQUIREMENTS

- IBM PC compatible computer with an RS-232C serial port (38400 bps or faster)
- Microsoft Windows 95 or Windows 98
- Intel i486DX processor or faster (Pentium 100 MHz or faster recommended)
- At least 16 MB RAM and 10 MB of hard disk space
- 640×480 pixel display (800×600 pixel display recommended)

■ ADJUSTMENT SOFTWARE INSTALLATION

- ① Boot up Windows.
- Quit all applications when Windows is running.
- ② Insert the cloning software CD-ROM into the appropriate CD-ROM drive.
- ③ Select 'Run' from the [Start] menu.
- ④ Type the setup program name using the full path name, then push the [Enter] key. (For example; D:\ setup)
- ⑤ Follow the prompts.
- ⑥ Program group 'CS-M88 ADJ' appears in the 'Programs' folder of the [Start] menu.

■ STARTING SOFTWARE ADJUSTMENT

- ① Connect IC-M87 and PC with the optional OPC-966 and the RS-232C cable.
- ② Boot up Windows, and turn the transceiver power ON.
- ③ Click the program group 'CS-M88 ADJ' in the 'Programs' folder of the [Start] menu, then CS-M88 ADJ's window is appeared.
- ④ Click 'Connect' on the CS-M88 ADJ's window, then appears IC-M87's up-to-date condition.
- ⑤ Set or modify adjustment data as desired.

IBM is a registered trademark of International Business Machines Corporation in the U.S.A. and other countries. Microsoft and Windows are registered trademarks of Microsoft Corporation in the U.S.A. and other countries. Screen shots produced with permission from Microsoft Corporation. All other products or brands are registered trademarks or trademarks of their respective holders.

• CONNECTION

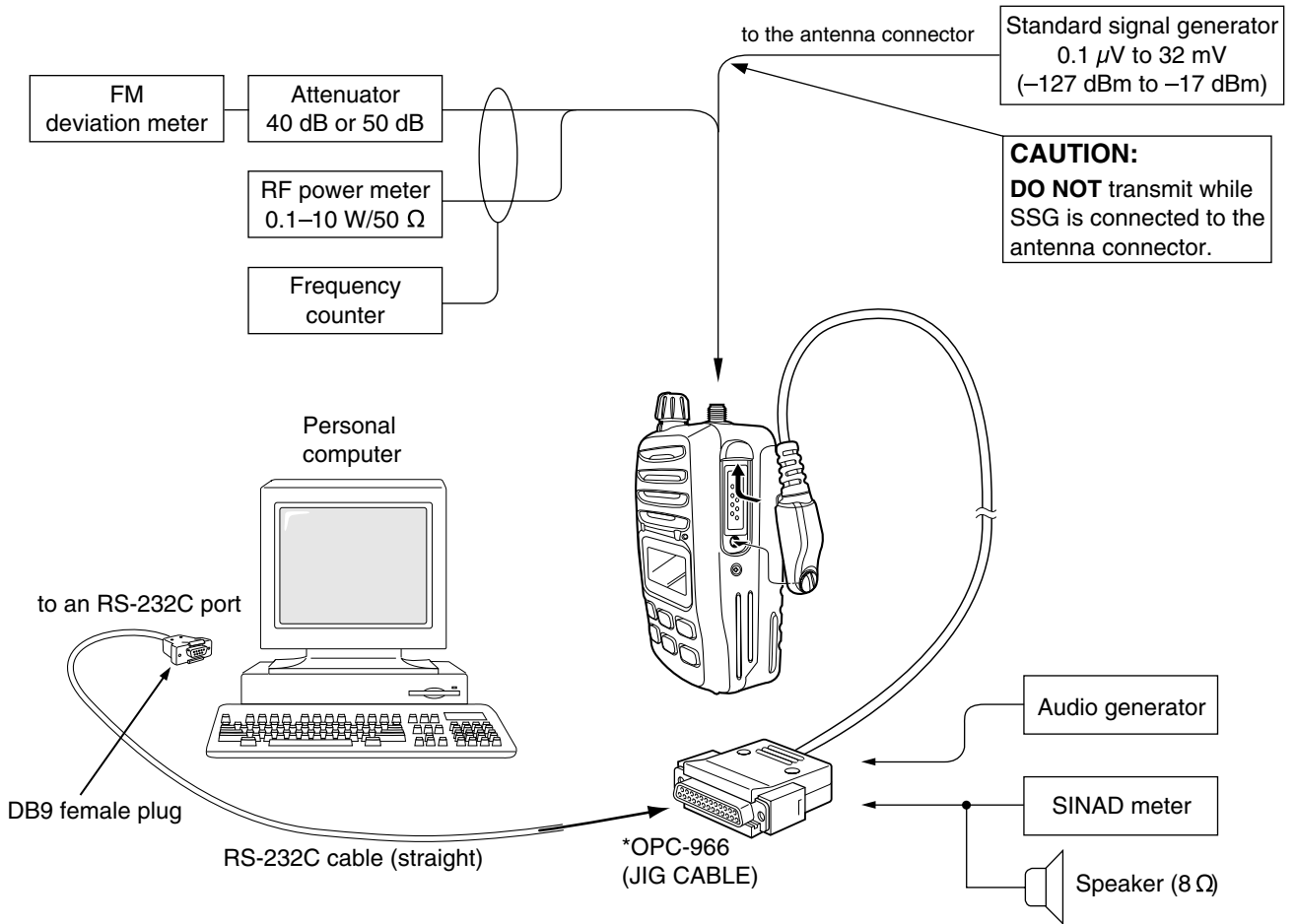

• *OPC-966 (JIG CABLE)

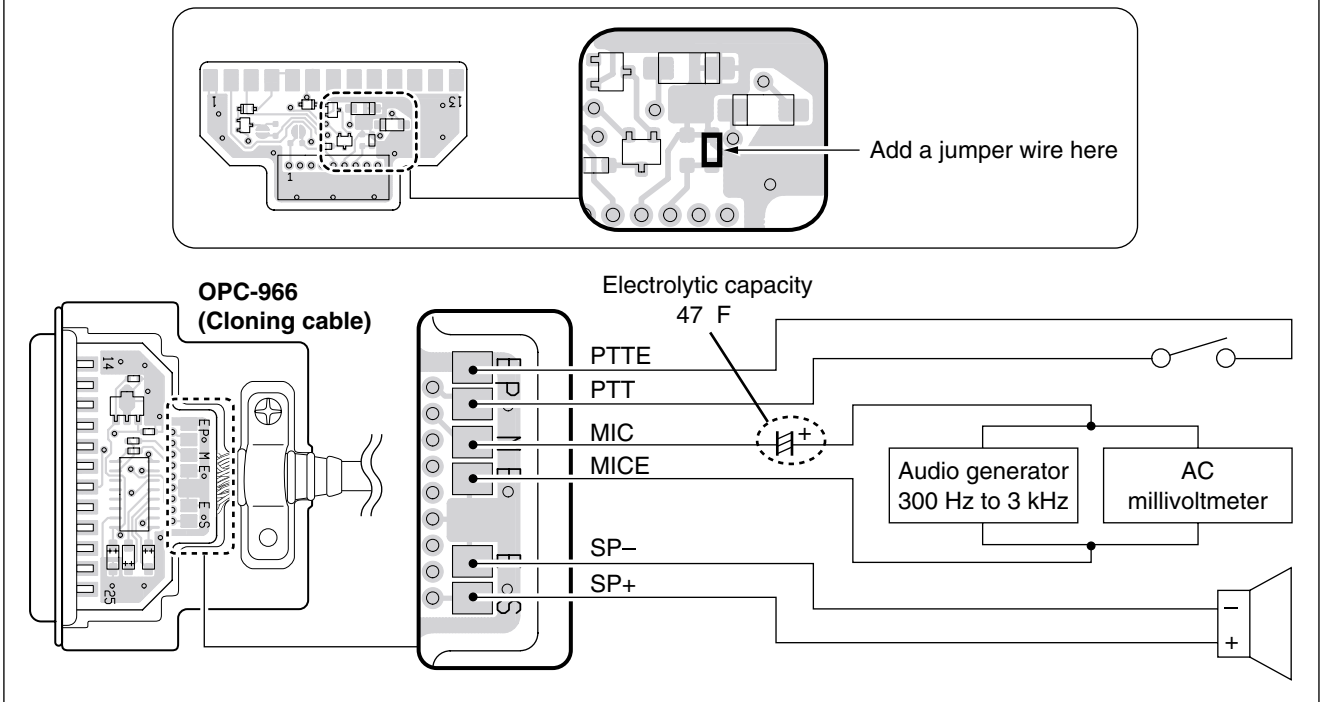

• SCREEN DISPLAY EXAMPLE

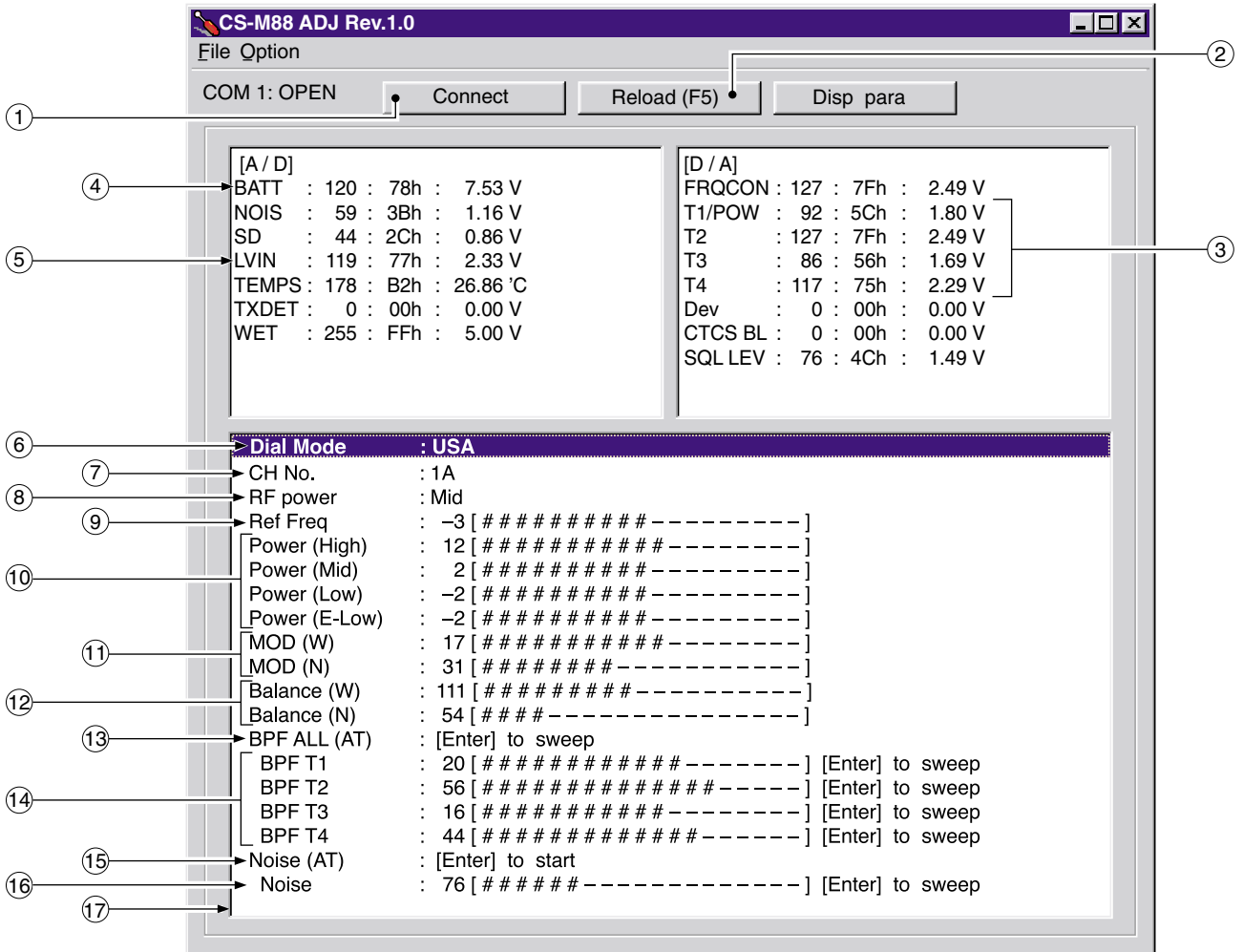

NOTE: The above values for settings are example only.
Each transceiver has its own specific values for each setting.

- | | |
|-------------------------------------|-----------------------------------------|
| ① : Transceiver's connection state | ⑨ : Reference frequency |
| ② : Reload adjustment data | ⑩ : RF output power |
| ③ : Receive sensitivity measurement | ⑪ : FM deviation |
| ④ : Connected battery voltage | ⑫ : Modulation balance |
| ⑤ : PLL lock voltage | ⑬ : Receive sensitivity (automatically) |
| ⑥ : Dial mode select | ⑭ : Receive sensitivity (manually) |
| ⑦ : Operating channel select | ⑮ : Squelch level (automatically) |
| ⑧ : RF output power select | ⑯ : Squelch level (manually) |
| | ⑰ : Adjustment items |

5-2 SOFTWARE ADJUSTMENTS

Select an operation using [↑] / [↓] keys, then set specified value using [←] / [→] keys on the connected computer keyboard.

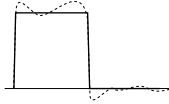
ADJUSTMENT	ADJUSTMENT CONDITION	MEASUREMENT		VALUE
		UNIT	LOCATION	
PLL LOCK VOLTAGE	1 <ul style="list-style-type: none"> • Operating channel : center frequency • Receiving 	MAIN	Connect the digital multimeter to the check point LV.	1.5–3.0 V (Verify) 1.85–3.35 V*1 (Verify)
	2 <ul style="list-style-type: none"> • Operating channel : center frequency • Connect the RF power meter or 50 Ω dummy load to the antenna connector. • Transmitting 			1.8–3.3 V (Verify)
REFERENCE FREQUENCY	1 <ul style="list-style-type: none"> • Operating channel : center frequency • Connect the RF power meter or 50 Ω dummy load to the antenna connector. • Transmitting 	Top panel	Loosely couple the frequency counter to the antenna connector.	160.000000 MHz
OUTPUT POWER	1 <ul style="list-style-type: none"> • Operating channel : center frequency • [H/L] switch : High • Transmitting 	Top panel	Connect the RF power meter to the antenna connector.	5.0 W
	2 <ul style="list-style-type: none"> • [H/L] switch : Mid • Transmitting 			3.0 W
	3 <ul style="list-style-type: none"> • [H/L] switch : Low • Transmitting 			0.75 W
	4 <ul style="list-style-type: none"> • [H/L] switch : Extra low • Transmitting 			0.45 W
FM DEVIATION (Wide) For [MARINE]*1	1 <ul style="list-style-type: none"> • Operating channel : center frequency • Channel spacing : Wide • [H/L] switch : High • Connect the audio generator to the [MIC] jack and set as: 1.0 kHz/200 mV rms. • Set the FM deviation meter as: HPF : OFF LPF : 20 kHz De-emphasis : OFF Detector : (P–P)/2 • Transmitting 	Top panel	Connect the FM deviation meter to the antenna connector through the attenuator.	±4.15–4.25 kHz
	(Narrow) For [LAND]			2 <ul style="list-style-type: none"> • Channel spacing : Narrow • Transmitting
MODULATION BARANCE (Wide) For [LAND]	1 <ul style="list-style-type: none"> • Operating channel : center frequency • Channel spacing : Wide • [H/L] switch : High • Set the DTCS as : Code 007 • Transmitting 	Top panel	Connect the FM deviation meter with an oscilloscope to the antenna connector through the attenuator.	Set to flat wave form 
	(Narrow) For [LAND]			2 <ul style="list-style-type: none"> • Channel spacing : Narrow • Transmitting

*[FRG] only

[LAND] : LAND channel group

[MARINE] : MARINE channel group

• MAIN UNIT TOP VIEW

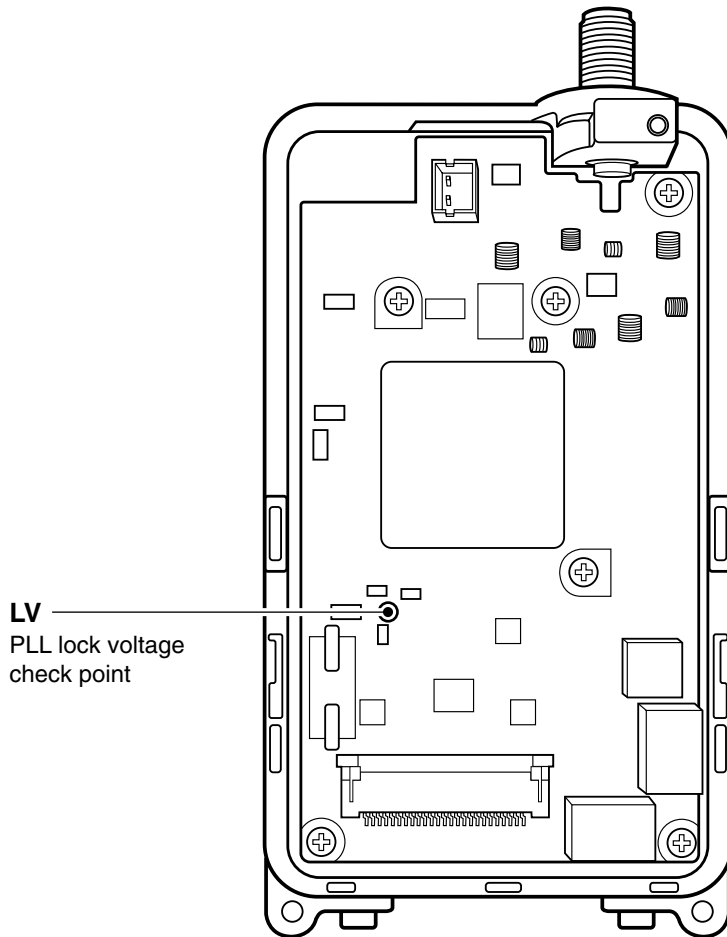

SOFTWARE ADJUSTMENT – continued

- Select an operation using [↑] / [↓] keys, then set specified value using [←] / [→] keys on the connected computer keyboard.
- “SQUELCH LEVEL ADJUSTMENT” must be performed after “RX SENSITIVITY ADJUSTMENT” is finished.
- “SQUELCH LEVEL ADJUSTMENT” must be performed when “RX SENSITIVITY ADJUSTMENT” is adjusted.

ADJUSTMENT	ADJUSTMENT CONDITION	MEASUREMENT		VALUE	
		UNIT	LOCATION		
RX SENSITIVITY [BPF T1]–[BPF T4] For [LAND]	1	<ul style="list-style-type: none"> • Operating frequency: center frequency • Channel spacing : Wide • Connect a standard signal generator to the antenna connector and set as: Level : 10 μV^* (–87 dBm) Modulation : OFF Deviation : ± 3.0 kHz • Receiving 	Top panel	Connect a SINAD meter with an 8 Ω load to the [SP] jack.	Minimum distortion level
	<p>CONVENIENT: The BPF T1–BPF T4 can be adjusted automatically.</p> <p>①-1: Set the cursor to “BPF ALL” on the adjustment program and then push [ENTER] key.</p> <p>①-2: The connected PC tunes BPF T1–BPF T4 to peak levels.</p> <p style="text-align: center;">or</p> <p>②-1: Set the cursor to one of BPF T1, T2, T3, or T4 as desired.</p> <p>②-2: Push [ENTER] key to start tuning.</p> <p>②-3: Repeat ②-1 and ②-2 to perform additional BPF tuning.</p>				
SQUELCH LEVEL [SQL] For [LAND]	1	<ul style="list-style-type: none"> • Operating frequency: center frequency • Channel spacing : Wide • Connect a standard signal generator to the antenna connector and set as: Level : 0.56 μV^* (–112 dBm) Modulation : 1 kHz Deviation : ± 3.0 kHz • Receiving 	Top panel	The “SQUELCH LEVEL” adjustment is adjusted by “ADJUSTMENT SOFTWARE”, automatically.	

*The output level of the standard signal generator (SSG) is indicated as the SSG’s open circuit.

*[FRG] only

[LAND] : LAND channel group

[MARINE] : MARINE channel group

SECTION 6 PARTS LIST

[VR UNIT]

REF NO.	ORDER NO.	DESCRIPTION	
R801	7210003130	VARIABLE	TP76N97N-13F-10KA-2497
C801	4030006900	S.CERAMIC	C1608 JB 1H 103K-T
C802	4030006860	S.CERAMIC	C1608 JB 1H 102K-T
W801	8900011900	CABLE	OPC-1192
W802	8900012030	CABLE	OPC-1231
EP801	0910055991	PCB	B 5982A

[CONNECTOR UNIT]

REF NO.	ORDER NO.	DESCRIPTION	
J851	6910015030	CONNECTOR	IMSA-9230B-1-09Z135-T
EP851	0910055632	PCB	B 5893B

[LOGIC UNIT]

REF NO.	ORDER NO.	DESCRIPTION	
IC421	1110001810	S.IC	TA7368F (TP1)
IC471	1110003800	S.IC	NJM2904V-TE1
IC481	1130007300	S.IC	TC4W66FU (TE12L)
IC491	1110003800	S.IC	NJM2904V-TE1
IC551	1110005350	S.IC	NJM2870F05-TE1
IC581	1110005770	S.IC	S-80942CNMC-G9C-T2
IC591	1130010390	S.IC	HN58X2416TI
IC661	1140011150	S.IC	μPD780316GC-511-9EB
IC681	1130007300	S.IC	TC4W66FU (TE12L)
Q411	1530003090	S.TRANSISTOR	2SC4213-B (TE85R)
Q431	1520000450	S.TRANSISTOR	2SB1132 T100 Q
Q432	1590001190	S.TRANSISTOR	XP6501-(TX) .AB
Q441	1530002850	S.TRANSISTOR	2SC4116-BL (TE85R)
Q442	1560001130	S.FET	CPH3403-TL
Q443	1560001130	S.FET	CPH3403-TL
Q444	1590000430	S.TRANSISTOR	DTC144EUA T106
Q461	1590002530	S.TRANSISTOR	UN911H (TX)
Q462	1590001920	S.TRANSISTOR	UN911F (TX)
Q501	1590000430	S.TRANSISTOR	DTC144EUA T106
Q531	1590001770	S.TRANSISTOR	XP1213 (TX)
Q532	1530002850	S.TRANSISTOR	2SC4116-BL (TE85R)
Q551	1520000450	S.TRANSISTOR	2SB1132 T100 Q
Q552	1590001190	S.TRANSISTOR	XP6501-(TX) .AB
Q553	1590000430	S.TRANSISTOR	DTC144EUA T106
Q561	1510000670	S.TRANSISTOR	2SA1588-GR (TE85R)
Q651	1590001770	S.TRANSISTOR	XP1213 (TX)
D451	1730002360	S.ZENER	MA8062-M (TX)
D452	1790000950	S.ZENER	MA8056-M (TX)
D453	1790000950	S.ZENER	MA8056-M (TX)
D454	1790000950	S.ZENER	MA8056-M (TX)
D581	1790001250	S.DIODE	MA2S111-(TX)
D601	1790000620	S.DIODE	MA77 (TX)
X601	6050011550	S.XTAL	CR-747 (9.8304 MHz)

[LOGIC UNIT]

REF NO.	ORDER NO.	DESCRIPTION	
L421	6200010230	S.COIL	EXCCL3216U1
R411	7030003560	S.RESISTOR	ERJ3GEYJ 103 V (10 kΩ)
R412	7030003560	S.RESISTOR	ERJ3GEYJ 103 V (10 kΩ)
R413	7030003620	S.RESISTOR	ERJ3GEYJ 333 V (33 kΩ)
R414	7030003820	S.RESISTOR	ERJ3GEYJ 155 V (1.5 MΩ)
R415	7030003820	S.RESISTOR	ERJ3GEYJ 155 V (1.5 MΩ)
R421	7030003260	S.RESISTOR	ERJ3GEYJ 330 V (33 Ω)
R422	7030003200	S.RESISTOR	ERJ3GEYJ 100 V (10 Ω)
R431	7030003610	S.RESISTOR	ERJ3GEYJ 273 V (27 kΩ)
R432	7030003800	S.RESISTOR	ERJ3GEYJ 105 V (1 MΩ)
R433	7030003480	S.RESISTOR	ERJ3GEYJ 222 V (2.2 kΩ)
R434	7030003480	S.RESISTOR	ERJ3GEYJ 222 V (2.2 kΩ)
R435	7030003500	S.RESISTOR	ERJ3GEYJ 332 V (3.3 kΩ)
R441	7030003760	S.RESISTOR	ERJ3GEYJ 474 V (470 kΩ)
R442	7030003760	S.RESISTOR	ERJ3GEYJ 474 V (470 kΩ)
R443	7030003680	S.RESISTOR	ERJ3GEYJ 104 V (100 kΩ)
R451	7030003280	S.RESISTOR	ERJ3GEYJ 470 V (47 Ω)
R452	7030003440	S.RESISTOR	ERJ3GEYJ 102 V (1 kΩ)
R453	7410000950	S.ARRAY	EXB-V8V 102JV
R454	7030003560	S.RESISTOR	ERJ3GEYJ 103 V (10 kΩ)
R461	7030003620	S.RESISTOR	ERJ3GEYJ 333 V (33 kΩ)
R462	7030003520	S.RESISTOR	ERJ3GEYJ 472 V (4.7 kΩ)
R463	7030003480	S.RESISTOR	ERJ3GEYJ 222 V (2.2 kΩ)
R464	7030003580	S.RESISTOR	ERJ3GEYJ 153 V (15 kΩ)
R465	7030003690	S.RESISTOR	ERJ3GEYJ 124 V (120 kΩ)
R466	7030003560	S.RESISTOR	ERJ3GEYJ 103 V (10 kΩ)
R467	7030003400	S.RESISTOR	ERJ3GEYJ 471 V (47 Ω)
R468	7030003680	S.RESISTOR	ERJ3GEYJ 104 V (100 kΩ)
R469	7030003730	S.RESISTOR	ERJ3GEYJ 274 V (270 kΩ)
R470	7030003680	S.RESISTOR	ERJ3GEYJ 104 V (100 kΩ)
R471	7030003640	S.RESISTOR	ERJ3GEYJ 473 V (47 kΩ)
R472	7030003590	S.RESISTOR	ERJ3GEYJ 183 V (18 kΩ)
R473	7030003520	S.RESISTOR	ERJ3GEYJ 472 V (4.7 kΩ)
R474	7030003520	S.RESISTOR	ERJ3GEYJ 472 V (4.7 kΩ)
R475	7030010290	S.RESISTOR	ERJ3GEYF 293 V (27 kΩ)
R476	7030004740	S.RESISTOR	ERJ3GEYF 392 V (3.9 kΩ)
R477	7030004730	S.RESISTOR	ERJ3GEYF 222 V (2.2 kΩ)
R478	7030003520	S.RESISTOR	ERJ3GEYJ 472 V (4.7 kΩ)
R481	7030003680	S.RESISTOR	ERJ3GEYJ 104 V (100 kΩ)
R482	7030003680	S.RESISTOR	ERJ3GEYJ 104 V (100 kΩ)
R491	7030003580	S.RESISTOR	ERJ3GEYJ 153 V (15 kΩ)
R492	7030003720	S.RESISTOR	ERJ3GEYJ 224 V (220 kΩ)
R493	7030003770	S.RESISTOR	ERJ3GEYJ 564 V (560 kΩ)
R494	7030003680	S.RESISTOR	ERJ3GEYJ 104 V (100 kΩ)
R495	7030003520	S.RESISTOR	ERJ3GEYJ 472 V (4.7 kΩ)
R496	7030003720	S.RESISTOR	ERJ3GEYJ 224 V (220 kΩ)
R497	7030003710	S.RESISTOR	ERJ3GEYJ 184 V (180 kΩ)
R498	7030003680	S.RESISTOR	ERJ3GEYJ 104 V (100 kΩ)
R501	7030003680	S.RESISTOR	ERJ3GEYJ 104 V (100 kΩ)
R502	7030003620	S.RESISTOR	ERJ3GEYJ 333 V (33 kΩ)
R503	7030003690	S.RESISTOR	ERJ3GEYJ 124 V (120 kΩ)
R504	7030003560	S.RESISTOR	ERJ3GEYJ 103 V (10 kΩ)
R511	7030003610	S.RESISTOR	ERJ3GEYJ 273 V (27 kΩ)
R512	7030003700	S.RESISTOR	ERJ3GEYJ 154 V (150 kΩ)
R513	7030003590	S.RESISTOR	ERJ3GEYJ 183 V (18 kΩ)
R521	7030003420	S.RESISTOR	ERJ3GEYJ 681 V (680 Ω)
R531	7030003600	S.RESISTOR	ERJ3GEYJ 223 V (22 kΩ)
R532	7030003600	S.RESISTOR	ERJ3GEYJ 223 V (22 kΩ)
R533	7030003650	S.RESISTOR	ERJ3GEYJ 563 V (56 kΩ)
R534	7030003710	S.RESISTOR	ERJ3GEYJ 184 V (180 kΩ)
R535	7030003560	S.RESISTOR	ERJ3GEYJ 103 V (10 kΩ)
R536	7030003640	S.RESISTOR	ERJ3GEYJ 473 V (47 kΩ)
R537	7030003640	S.RESISTOR	ERJ3GEYJ 473 V (47 kΩ)
R538	7030003440	S.RESISTOR	ERJ3GEYJ 102 V (1 kΩ)
R539	7030003640	S.RESISTOR	ERJ3GEYJ 473 V (47 kΩ)
R540	7030003580	S.RESISTOR	ERJ3GEYJ 153 V (15 kΩ)
R551	7030003560	S.RESISTOR	ERJ3GEYJ 103 V (10 kΩ)
R552	7030003480	S.RESISTOR	ERJ3GEYJ 222 V (2.2 kΩ)
R553	7030003600	S.RESISTOR	ERJ3GEYJ 223 V (22 kΩ)
R561	7030003560	S.RESISTOR	ERJ3GEYJ 103 V (10 kΩ)
R562	7030003520	S.RESISTOR	ERJ3GEYJ 472 V (4.7 kΩ)
R571	7030005930	S.RESISTOR	ERJ3GEYF 334 V (330 kΩ)
R572	7030008090	S.RESISTOR	ERJ3GEYF 1503 V (150 kΩ)
R581	7030003560	S.RESISTOR	ERJ3GEYJ 103 V (10 kΩ)

S.=Surface mount

[LOGIC UNIT]

REF NO.	ORDER NO.	DESCRIPTION	
R582	7030003440	S.RESISTOR	ERJ3GEYJ 102 V (1 kΩ)
R583	7410000750	S.ARRAY	EXB-V4V 104JV (100 kΩ)
R591	7030003560	S.RESISTOR	ERJ3GEYJ 103 V (10 kΩ)
R592	7030003560	S.RESISTOR	ERJ3GEYJ 103 V (10 kΩ)
R601	7030003200	S.RESISTOR	ERJ3GEYJ 100 V (10 Ω)
R602	7030003800	S.RESISTOR	ERJ3GEYJ 105 V (1 MΩ)
R603	7030003570	S.RESISTOR	ERJ3GEYJ 123 V (12 kΩ)
R604	7030003570	S.RESISTOR	ERJ3GEYJ 123 V (12 kΩ)
R605	7030003570	S.RESISTOR	ERJ3GEYJ 123 V (12 kΩ)
R606	7030003440	S.RESISTOR	ERJ3GEYJ 102 V (1 kΩ)
R611	7030003560	S.RESISTOR	ERJ3GEYJ 103 V (10 kΩ)
R612	7030003520	S.RESISTOR	ERJ3GEYJ 472 V (4.7 kΩ)
R621	7030003760	S.RESISTOR	ERJ3GEYJ 474 V (470 kΩ)
R631	7410000800	S.ARRAY	EXB-V8V 103JV (10 kΩ)
R632	7030003680	S.RESISTOR	ERJ3GEYJ 104 V (100 kΩ)
R633	7410000800	S.ARRAY	EXB-V8V 103JV (10 kΩ)
R651	7030003380	S.RESISTOR	ERJ3GEYJ 331 V (330 Ω)
R652	7030003360	S.RESISTOR	ERJ3GEYJ 221 V (220 Ω)
R653	7030003440	S.RESISTOR	ERJ3GEYJ 102 V (1 kΩ)
R654	7030003420	S.RESISTOR	ERJ3GEYJ 681 V (680 Ω)
R681	7030003790	S.RESISTOR	ERJ3GEYJ 824 V (820 kΩ)
R682	7030003730	S.RESISTOR	ERJ3GEYJ 274 V (270 kΩ)
R683	7030003750	S.RESISTOR	ERJ3GEYJ 394 V (390 kΩ)
R684	7030003830	S.RESISTOR	ERJ3GEYJ 185 V (1.8 MΩ)
C411	4030017480	S.CERAMIC	C1608 JB 1A 474K-T
C412	4550006140	S.TANTALUM	ECST1EY474R
C413	4030011600	S.CERAMIC	C1608 JB 1E 104K-T
C421	4550006210	S.TANTALUM	ECST1CX106R
C422	4030011600	S.CERAMIC	C1608 JB 1E 104K-T
C423	4030006860	S.CERAMIC	C1608 JB 1H 102K-T
C424	4550006700	S.TANTALUM	ECST1AY106R
C425	4030007090	S.CERAMIC	C1608 CH 1H 470J-T
C426	4030008920	S.CERAMIC	C1608 JB 1H 473K-T
C427	4550007050	S.TANTALUM	ECST1AD157R
C431	4030017490	S.CERAMIC	C1608 JB 1A 105K-T
C432	4030011600	S.CERAMIC	C1608 JB 1E 104K-T
C441	4030007090	S.CERAMIC	C1608 CH 1H 470J-T
C450	4030006900	S.CERAMIC	C1608 JB 1H 103K-T
C451	4030006860	S.CERAMIC	C1608 JB 1H 102K-T
C452	4030006860	S.CERAMIC	C1608 JB 1H 102K-T
C453	4030011600	S.CERAMIC	C1608 JB 1E 104K-T
C454	4030007090	S.CERAMIC	C1608 CH 1H 470J-T
C455	4030011600	S.CERAMIC	C1608 JB 1E 104K-T
C456	4030011600	S.CERAMIC	C1608 JB 1E 104K-T
C457	4030007090	S.CERAMIC	C1608 CH 1H 470J-T
C461	4030006860	S.CERAMIC	C1608 JB 1H 102K-T
C462	4030011600	S.CERAMIC	C1608 JB 1E 104K-T
C463	4030006900	S.CERAMIC	C1608 JB 1H 103K-T
C464	4030011600	S.CERAMIC	C1608 JB 1E 104K-T
C465	4030006900	S.CERAMIC	C1608 JB 1H 103K-T
C466	4030011600	S.CERAMIC	C1608 JB 1E 104K-T
C467	4550006700	S.TANTALUM	ECST1AY106R
C471	4030006900	S.CERAMIC	C1608 JB 1H 103K-T
C472	4550006950	S.TANTALUM	ECST0JX476R
C473	4030006900	S.CERAMIC	C1608 JB 1H 103K-T
C481	4030006900	S.CERAMIC	C1608 JB 1H 103K-T
C491	4030006900	S.CERAMIC	C1608 JB 1H 103K-T
C492	4030017490	S.CERAMIC	C1608 JB 1A 105K-T
C502	4030007150	S.CERAMIC	C1608 CH 1H 151J-T
C503	4030006880	S.CERAMIC	C1608 JB 1H 472K-T
C504	4030009980	S.CERAMIC	C1608 JB 1H 152K-T
C511	4030008650	S.CERAMIC	C1608 JB 1H 332K-T
C512	4030011600	S.CERAMIC	C1608 JB 1E 104K-T
C521	4030011600	S.CERAMIC	C1608 JB 1E 104K-T
C522	4030008880	S.CERAMIC	C1608 JB 1H 223K-T
C531	4030008920	S.CERAMIC	C1608 JB 1H 473K-T
C532	4030008910	S.CERAMIC	C1608 JB 1H 393K-T
C533	4030011600	S.CERAMIC	C1608 JB 1E 104K-T
C534	4030009490	S.CERAMIC	C1608 JB 1H 821K-T
C535	4030006900	S.CERAMIC	C1608 JB 1H 103K-T
C536	4030008920	S.CERAMIC	C1608 JB 1H 473K-T
C551	4550006710	S.TANTALUM	ECST1AX226R
C552	4030006860	S.CERAMIC	C1608 JB 1H 102K-T
C553	4550006820	S.TANTALUM	ECST1DX106R
C554	4030006900	S.CERAMIC	C1608 JB 1H 103K-T
C555	4030011810	S.CERAMIC	C1608 JB 1A 224K-T
C556	4030006860	S.CERAMIC	C1608 JB 1H 102K-T
C557	4550006710	S.TANTALUM	ECST1AX226R
C561	4030006900	S.CERAMIC	C1608 JB 1H 103K-T
C571	4030006900	S.CERAMIC	C1608 JB 1H 103K-T

[LOGIC UNIT]

REF NO.	ORDER NO.	DESCRIPTION	
C581	4030008890	S.CERAMIC	C1608 JB 1H 273K-T
C582	4030007090	S.CERAMIC	C1608 CH 1H 470J-T
C591	4030006900	S.CERAMIC	C1608 JB 1H 103K-T
C601	4030007050	S.CERAMIC	C1608 CH 1H 220J-T
C602	4030006980	S.CERAMIC	C1608 CH 1H 070D-T
C603	4030007070	S.CERAMIC	C1608 CH 1H 330J-T
C604	4030006900	S.CERAMIC	C1608 JB 1H 103K-T
C605	4030007090	S.CERAMIC	C1608 CH 1H 470J-T
C606	4030006900	S.CERAMIC	C1608 JB 1H 103K-T
C611	4030006860	S.CERAMIC	C1608 JB 1H 102K-T
C612	4030008880	S.CERAMIC	C1608 JB 1H 223K-T
C621	4030006860	S.CERAMIC	C1608 JB 1H 102K-T
C622	4030006860	S.CERAMIC	C1608 JB 1H 102K-T
C623	4030006860	S.CERAMIC	C1608 JB 1H 102K-T
C641	4550006710	S.TANTALUM	ECST1AX226R
C642	4030006900	S.CERAMIC	C1608 JB 1H 103K-T
C643	4030006900	S.CERAMIC	C1608 JB 1H 103K-T
C661	4030008920	S.CERAMIC	C1608 JB 1H 473K-T
C662	4030008920	S.CERAMIC	C1608 JB 1H 473K-T
C663	4030008920	S.CERAMIC	C1608 JB 1H 473K-T
C664	4030008920	S.CERAMIC	C1608 JB 1H 473K-T
C665	4030008920	S.CERAMIC	C1608 JB 1H 473K-T
C666	4030008900	S.CERAMIC	C1608 JB 1H 333K-T
C667	4030008920	S.CERAMIC	C1608 JB 1H 473K-T
C668	4030008920	S.CERAMIC	C1608 JB 1H 473K-T
C669	4030008920	S.CERAMIC	C1608 JB 1H 473K-T
C670	4030008920	S.CERAMIC	C1608 JB 1H 473K-T
C671	4030011600	S.CERAMIC	C1608 JB 1E 104K-T
C681	4030011600	S.CERAMIC	C1608 JB 1E 104K-T
C682	4030017480	S.CERAMIC	C1608 JB 1A 474K-T
C683	4030017480	S.CERAMIC	C1608 JB 1A 474K-T
C684	4030017480	S.CERAMIC	C1608 JB 1A 474K-T
C685	4030017480	S.CERAMIC	C1608 JB 1A 474K-T
J401	6510023520	S.CONNECTOR	54104-3692
J411	6510018350	S.CONNECTOR	S3B-ZR-SM3A-TF
DS651	5040002660	S.LED	FY1101F-TR (LED)
DS652	5040002660	S.LED	FY1101F-TR (LED)
DS653	5040002310	S.LED	SML-311YTT86
DS654	5040002310	S.LED	SML-311YTT86
DS681	5030002480	LCD	L2-0390TAY
MC461	7700002630	MICROPHONE	SKB-2246T-C33
S461	2230001060	S.SWITCH	EVQ-PUL 02K
S641	2230001060	S.SWITCH	EVQ-PUL 02K
W461	9026007060	WIRE	24/06/030/W01/W01
W462	9026007050	WIRE	24/02/030/W01/W01
W522	7030003860	S.JUMPER	ERJ3GE JPW V
W523	7030003860	S.JUMPER	ERJ3GE JPW V
W581	7030003860	S.JUMPER	ERJ3GE JPW V
EP401	0910055613	PCB	B 5891C
EP451	6910012350	S.BEAD	MMZ1608Y 102BT
EP452	6910012350	S.BEAD	MMZ1608Y 102BT
EP454	6910012350	S.BEAD	MMZ1608Y 102BT
EP458	6910012350	S.BEAD	MMZ1608Y 102BT
EP459	6910012350	S.BEAD	MMZ1608Y 102BT
EP681	8930059150	LCD CONTACT	SRCN-2600-SP-N-W

S.=Surface mount

[MAIN UNIT]

REF NO.	ORDER NO.	DESCRIPTION	
IC1	1140005990	S.IC	MB15A02PFV1-G-BND-ER
IC141	1110002750	S.IC	TA75S01F (TE85R)
IC231	1110003200	S.IC	TA31136FN (EL)
IC251	1190000350	S.IC	M62363FP-650C
IC261	1110003800	S.IC	NJM2904V-TE1
IC281	1130007300	S.IC	TC4W66FU (TE12L)
IC282	1130006220	S.IC	TC4W53FU (TE12L)
IC311	1120002830	S.IC	NJM2125F-TE1
IC331	1190001860	S.IC	EW-460-FT
IC341	1130007570	S.IC	BU4094BCFV-E2
IC382	1110003800	S.IC	NJM2904V-TE1
IC383	1130007990	S.IC	TC3W03FU (TE12L)
Q1	1560000840	S.FET	2SK1829 (TE85R)
Q2	1530002600	S.TRANSISTOR	2SC4215-O (TE85R)
Q3	1560000540	S.FET	2SK880-Y (TE85R)
Q41	1530002920	S.TRANSISTOR	2SC4226-T1 R25
Q47	1590001190	S.TRANSISTOR	XP6501-(TX) .AB
Q51	1530002920	S.TRANSISTOR	2SC4226-T1 R25
Q61	1530002380	S.TRANSISTOR	2SC4215-Y (TE85R)
Q62	1530002380	S.TRANSISTOR	2SC4215-Y (TE85R)
Q71	1530002380	S.TRANSISTOR	2SC4215-Y (TE85R)
Q81	1590001400	S.TRANSISTOR	XP1214 (TX)
Q82	1590000430	S.TRANSISTOR	DTC144EUA T106
Q91	1530003420	S.TRANSISTOR	2SC5110-O (TE85R)
Q101	1560001240	S.FET	RD01MUS1
Q111	1560001230	S.FET	RD07MVS1
Q141	1590000720	S.TRANSISTOR	DTA144EUA T106
Q165	1580000750	S.FET	3SK294 (TE85L)
Q171	1560000840	S.FET	2SK1829 (TE85R)
Q191	1580000760	S.FET	3SK299-T1 U73
Q211	1530002600	S.TRANSISTOR	2SC4215-O (TE85R)
Q221	1530002690	S.TRANSISTOR	2SC4116-GR (TE85R)
Q231	1590000720	S.TRANSISTOR	DTA144EUA T106
Q232	1530003310	S.TRANSISTOR	2SC5107-O (TE85R)
Q291	1590001650	S.TRANSISTOR	XP4601 (TX)
Q321	1510000670	S.TRANSISTOR	2SA1588-GR (TE85R)
Q322	1510000670	S.TRANSISTOR	2SA1588-GR (TE85R)
Q323	1510000670	S.TRANSISTOR	2SA1588-GR (TE85R)
Q381	1590000430	S.TRANSISTOR	DTC144EUA T106
D1	1790001250	S.DIODE	MA2S111-(TX)
D2	1750000830	S.VARICAP	HVC362TRF
D3	1790001250	S.DIODE	MA2S111-(TX)
D31	1750000710	S.VARICAP	HVC350BTRF
D32	1750000710	S.VARICAP	HVC350BTRF
D33	1750000710	S.VARICAP	HVC350BTRF
D34	1750000710	S.VARICAP	HVC350BTRF
D35	1750000710	S.VARICAP	HVC350BTRF
D36	1750000710	S.VARICAP	HVC350BTRF
D37	1750000710	S.VARICAP	HVC350BTRF
D38	1750000710	S.VARICAP	HVC350BTRF
D39	1720000400	S.VARICAP	1SV245 (TPH3)
D40	1750000580	S.DIODE	1SV307 (TPH3)
D91	1790000620	S.DIODE	MA77 (TX)
D92	1790000620	S.DIODE	MA77 (TX)
D121	1790001670	S.DIODE	RB706F-40T106
D131	1750000580	S.DIODE	1SV307 (TPH3)
D132	1790001210	S.DIODE	1SS375-TL
D141	1790001240	S.DIODE	MA2S728-(TX)
D151	1750000580	S.DIODE	1SV307 (TPH3)
D152	1790000620	S.DIODE	MA77 (TX)
D153	1750000580	S.DIODE	1SV307 (TPH3)
D154	1720000780	S.VARICAP	HVU350B TRF
D155	1720000780	S.VARICAP	HVU350B TRF
D171	1790001250	S.DIODE	MA2S111-(TX)
D181	1720000780	S.VARICAP	HVU350B TRF
D182	1720000780	S.VARICAP	HVU350B TRF
D231	1750000520	S.DIODE	DAN222TL
D232	1750000520	S.DIODE	DAN222TL
FI211	2030000230	S.MONOLITH	FL-355 (31.05 MHz)
FI231	2020001270	CERAMIC	CFWLB450KE2A-B0 (CFWM450E)
FI232	2020001410	CERAMIC	CFWLB450KGFA-B0 (CFWM450G)

[MAIN UNIT]

REF NO.	ORDER NO.	DESCRIPTION	
X1	6050011070	S.XTAL	CR-664A (15.300 MHz)
X231	6070000190	S.DISCRIMINATOR	CDBC8450KCAY24-R0
L31	6200005540	S.COIL	ELJNC R47K-F
L32	6200008450	S.COIL	0.35-1.6-5TL 28N
L33	6200005540	S.COIL	ELJNC R47K-F
L34	6200008390	S.COIL	0.25-1.9-9TL
L35	6200008380	S.COIL	0.28-1.0-11TR 42N
L41	6200008190	S.COIL	0.25-1.9-8TL 80N
L47	6200002610	S.COIL	NL 252018T-R47J
L51	6200008390	S.COIL	0.25-1.9-9TL
L61	6200006980	S.COIL	ELJRE R10G-F
L62	6200006980	S.COIL	ELJRE R10G-F
L71	6200006980	S.COIL	ELJRE R10G-F
L72	6200005720	S.COIL	ELJRE 33NG-F
L81	6200007170	S.COIL	MLF1608A 3R3K-T
L82	6200007170	S.COIL	MLF1608A 3R3K-T
L92	6200005710	S.COIL	ELJRE 27NG-F
L102	6200007690	S.COIL	LQW2BHN18NJ01L (LQN21A 18NJ04)
L112	6200008260	S.COIL	0.30-1.7-8TL 60N
L121	6200008510	S.COIL	0.30-0.9-4TR 10.5N
L122	6200008230	S.COIL	0.30-1.3-5TL 22N
L123	6200008280	S.COIL	0.30-1.7-7TL 50N
L124	6200003090	S.COIL	NL 322522T-2R7J-3
L131	6200009800	S.COIL	0.26-1.1-7TR 30N
L132	6200008580	S.COIL	0.30-1.4-6TL 32N
L151	6200008280	S.COIL	0.30-1.7-7TL 50N
L152	6200008280	S.COIL	0.30-1.7-7TL 50N
L153	6200003960	S.COIL	MLF1608A 1R0K-T
L154	6200007750	S.COIL	LQW2BHN56NJ01L (LQN21A 56NJ04)
L155	6200007750	S.COIL	LQW2BHN56NJ01L (LQN21A 56NJ04)
L156	6200002150	S.COIL	ELJNC 56NK-F
L165	6200003960	S.COIL	MLF1608A 1R0K-T
L166	6200007750	S.COIL	LQW2BHN56NJ01L (LQN21A 56NJ04)
L181	6200007750	S.COIL	LQW2BHN56NJ01L (LQN21A 56NJ04)
L191	6200005540	S.COIL	ELJNC R47K-F
L203	6200009180	S.COIL	ELJRE R10J-F3
L221	6200001980	S.COIL	NL 252018T-1R0J
L222	6200001980	S.COIL	NL 252018T-1R0J
R1	7030003700	S.RESISTOR	ERJ3GEYJ 154 V (150 kΩ)
R2	7030003240	S.RESISTOR	ERJ3GEYJ 220 V (22 Ω)
R3	7410000950	S.ARRAY	EXB-V8V 102JV
R4	7510001660	S.THRMISTOR	NTCG16 4LH 473KT
R5	7030003940	S.RESISTOR	ERJ3GEYJ 104 V (100 kΩ)
R6	7030003560	S.RESISTOR	ERJ3GEYJ 103 V (10 kΩ)
R7	7030003610	S.RESISTOR	ERJ3GEYJ 273 V (27 kΩ)
R8	7030003690	S.RESISTOR	ERJ3GEYJ 124 V (120 kΩ)
R9	7030003560	S.RESISTOR	ERJ3GEYJ 103 V (10 kΩ)
R10	7030003760	S.RESISTOR	ERJ3GEYJ 474 V (470 kΩ)
R11	7030003640	S.RESISTOR	ERJ3GEYJ 473 V (47 kΩ)
R12	7030003280	S.RESISTOR	ERJ3GEYJ 470 V (47 Ω)
R13	7030003670	S.RESISTOR	ERJ3GEYJ 823 V (82 kΩ)
R14	7030003640	S.RESISTOR	ERJ3GEYJ 473 V (47 kΩ)
R15	7030003450	S.RESISTOR	ERJ3GEYJ 122 V (1.2 kΩ)
R16	7030003290	S.RESISTOR	ERJ3GEYJ 560 V (56 Ω)
R17	7030003320	S.RESISTOR	ERJ3GEYJ 101 V (100 Ω)
R18	7030003440	S.RESISTOR	ERJ3GEYJ 102 V (1 kΩ)
R19	7030003400	S.RESISTOR	ERJ3GEYJ 471 V (470 Ω)
R20	7030003440	S.RESISTOR	ERJ3GEYJ 102 V (1 kΩ)
R21	7030003560	S.RESISTOR	ERJ3GEYJ 103 V (10 kΩ)
R22	7030003550	S.RESISTOR	ERJ3GEYJ 822 V (8.2 kΩ)
R31	7030003200	S.RESISTOR	ERJ3GEYJ 100 V (10 Ω)
R32	7030003440	S.RESISTOR	ERJ3GEYJ 102 V (1 kΩ)
R33	7030003440	S.RESISTOR	ERJ3GEYJ 102 V (1 kΩ)
R34	7030003200	S.RESISTOR	ERJ3GEYJ 100 V (10 Ω)
R35	7030003710	S.RESISTOR	ERJ3GEYJ 184 V (180 kΩ)
R36	7030003640	S.RESISTOR	ERJ3GEYJ 473 V (47 kΩ)
R37	7030003680	S.RESISTOR	ERJ3GEYJ 104 V (100 kΩ)
R38	7030003640	S.RESISTOR	ERJ3GEYJ 473 V (47 kΩ)
R39	7030003680	S.RESISTOR	ERJ3GEYJ 104 V (100 kΩ)
R40	7030003520	S.RESISTOR	ERJ3GEYJ 472 V (4.7 kΩ)
R41	7030003460	S.RESISTOR	ERJ3GEYJ 152 V (1.5 kΩ)
R42	7030003510	S.RESISTOR	ERJ3GEYJ 392 V (3.9 kΩ)
R43	7030004040	S.RESISTOR	ERJ3GEYJ 4R7 V (4.7 Ω)
R47	7030003480	S.RESISTOR	ERJ3GEYJ 222 V (2.2 kΩ)
R51	7030003490	S.RESISTOR	ERJ3GEYJ 272 V (2.7 kΩ)
R52	7030003530	S.RESISTOR	ERJ3GEYJ 562 V (5.6 kΩ)
R53	7030004040	S.RESISTOR	ERJ3GEYJ 4R7 V (4.7 Ω)
R61	7030003320	S.RESISTOR	ERJ3GEYJ 101 V (100 Ω)

S.=Surface mount

[MAIN UNIT]

REF NO.	ORDER NO.	DESCRIPTION	
R62	7030003660	S.RESISTOR	ERJ3GEYJ 683 V (68 kΩ)
R63	7030004040	S.RESISTOR	ERJ3GEYJ 4R7 V (4.7 Ω)
R64	7030003640	S.RESISTOR	ERJ3GEYJ 473 V (47 kΩ)
R65	7030003320	S.RESISTOR	ERJ3GEYJ 101 V (100 Ω)
R71	7030003660	S.RESISTOR	ERJ3GEYJ 683 V (68 kΩ)
R72	7030003360	S.RESISTOR	ERJ3GEYJ 221 V (220 Ω)
R81	7030003380	S.RESISTOR	ERJ3GEYJ 331 V (330 Ω)
R82	7030003390	S.RESISTOR	ERJ3GEYJ 391 V (390 Ω)
R83	7030003560	S.RESISTOR	ERJ3GEYJ 103 V (10 kΩ)
R91	7030003440	S.RESISTOR	ERJ3GEYJ 102 V (1 kΩ)
R92	7030003320	S.RESISTOR	ERJ3GEYJ 101 V (100 Ω)
R93	7030003560	S.RESISTOR	ERJ3GEYJ 103 V (10 kΩ)
R94	7030003460	S.RESISTOR	ERJ3GEYJ 152 V (1.5 kΩ)
R95	7030003400	S.RESISTOR	ERJ3GEYJ 471 V (470 Ω)
R96	7030003500	S.RESISTOR	ERJ3GEYJ 332 V (3.3 kΩ)
R97	7030003200	S.RESISTOR	ERJ3GEYJ 100 V (10 Ω)
R98	7030003320	S.RESISTOR	ERJ3GEYJ 101 V (100 Ω)
R101	7030003520	S.RESISTOR	ERJ3GEYJ 472 V (4.7 kΩ)
R102	7030003620	S.RESISTOR	ERJ3GEYJ 333 V (33 kΩ)
R103	7030003300	S.RESISTOR	ERJ3GEYJ 680 V (68 Ω)
R111	7030003200	S.RESISTOR	ERJ3GEYJ 100 V (10 Ω)
R112	7030003200	S.RESISTOR	ERJ3GEYJ 100 V (10 Ω)
R113	7030003520	S.RESISTOR	ERJ3GEYJ 472 V (4.7 kΩ)
R114	7030003680	S.RESISTOR	ERJ3GEYJ 104 V (100 kΩ)
R121	7030003580	S.RESISTOR	ERJ3GEYJ 153 V (15 kΩ)
R122	7030000280	S.RESISTOR	MCR10EZHZ 150 Ω (151)
R131	7030003670	S.RESISTOR	ERJ3GEYJ 823 V (82 kΩ)
R132	7030003560	S.RESISTOR	ERJ3GEYJ 103 V (10 kΩ)
R133	7030003580	S.RESISTOR	ERJ3GEYJ 153 V (15 kΩ)
R141	7030003700	S.RESISTOR	ERJ3GEYJ 154 V (150 kΩ)
R142	7030003630	S.RESISTOR	ERJ3GEYJ 393 V (39 kΩ)
R143	7030003480	S.RESISTOR	ERJ3GEYJ 222 V (2.2 kΩ)
R144	7030003490	S.RESISTOR	ERJ3GEYJ 272 V (2.7 kΩ)
R145	7030003570	S.RESISTOR	ERJ3GEYJ 123 V (12 kΩ)
R146	7030003560	S.RESISTOR	ERJ3GEYJ 103 V (10 kΩ)
R147	7030003700	S.RESISTOR	ERJ3GEYJ 154 V (150 kΩ)
R148	7030003320	S.RESISTOR	ERJ3GEYJ 101 V (100 Ω)
R149	7030003440	S.RESISTOR	ERJ3GEYJ 102 V (1 kΩ)
R151	7030003320	S.RESISTOR	ERJ3GEYJ 101 V (100 Ω)
R152	7030003680	S.RESISTOR	ERJ3GEYJ 104 V (100 kΩ)
R153	7030003720	S.RESISTOR	ERJ3GEYJ 224 V (220 kΩ)
R154	7030003560	S.RESISTOR	ERJ3GEYJ 103 V (10 kΩ)
R155	7030003720	S.RESISTOR	ERJ3GEYJ 224 V (220 kΩ)
R156	7030003560	S.RESISTOR	ERJ3GEYJ 103 V (10 kΩ)
R165	7030003590	S.RESISTOR	ERJ3GEYJ 183 V (18 kΩ)
R166	7030003700	S.RESISTOR	ERJ3GEYJ 154 V (150 kΩ)
R167	7030003400	S.RESISTOR	ERJ3GEYJ 471 V (470 Ω)
R171	7030003560	S.RESISTOR	ERJ3GEYJ 103 V (10 kΩ)
R172	7030003760	S.RESISTOR	ERJ3GEYJ 474 V (470 kΩ)
R173	7030003530	S.RESISTOR	ERJ3GEYJ 562 V (5.6 kΩ)
R174	7030003780	S.RESISTOR	ERJ3GEYJ 684 V (680 kΩ)
R175	7030003560	S.RESISTOR	ERJ3GEYJ 103 V (10 kΩ)
R181	7030003430	S.RESISTOR	ERJ3GEYJ 821 V (820 Ω)
R182	7030003720	S.RESISTOR	ERJ3GEYJ 224 V (220 kΩ)
R183	7030003560	S.RESISTOR	ERJ3GEYJ 103 V (10 kΩ)
R184	7030003720	S.RESISTOR	ERJ3GEYJ 224 V (220 kΩ)
R185	7030003560	S.RESISTOR	ERJ3GEYJ 103 V (10 kΩ)
R186	7030003520	S.RESISTOR	ERJ3GEYJ 472 V (4.7 kΩ)
R191	7030003330	S.RESISTOR	ERJ3GEYJ 121 V (120 Ω)
R192	7030003320	S.RESISTOR	ERJ3GEYJ 101 V (100 Ω)
R193	7030003500	S.RESISTOR	ERJ3GEYJ 332 V (3.3 kΩ)
R201	7030003440	S.RESISTOR	ERJ3GEYJ 102 V (1 kΩ)
R202	7030003560	S.RESISTOR	ERJ3GEYJ 103 V (10 kΩ)
R203	7030003400	S.RESISTOR	ERJ3GEYJ 471 V (470 Ω)
R204	7030003210	S.RESISTOR	ERJ3GEYJ 120 V (12 Ω)
R205	7030003400	S.RESISTOR	ERJ3GEYJ 471 V (470 Ω)
R206	7030003520	S.RESISTOR	ERJ3GEYJ 472 V (4.7 kΩ)
R211	7030003440	S.RESISTOR	ERJ3GEYJ 102 V (1 kΩ)
R213	7030003460	S.RESISTOR	ERJ3GEYJ 152 V (1.5 kΩ)
R214	7030003400	S.RESISTOR	ERJ3GEYJ 471 V (470 Ω)
R215	7030003690	S.RESISTOR	ERJ3GEYJ 124 V (120 kΩ)
R216	7030003420	S.RESISTOR	ERJ3GEYJ 681 V (680 Ω)
R221	7030003780	S.RESISTOR	ERJ3GEYJ 684 V (680 kΩ)
R222	7030003450	S.RESISTOR	ERJ3GEYJ 122 V (1.2 kΩ)
R223	7030003340	S.RESISTOR	ERJ3GEYJ 151 V (150 Ω)
R231	7030003500	S.RESISTOR	ERJ3GEYJ 332 V (3.3 kΩ)
R232	7030003280	S.RESISTOR	ERJ3GEYJ 470 V (47 Ω)
R233	7030003580	S.RESISTOR	ERJ3GEYJ 153 V (15 kΩ)
R234	7030003600	S.RESISTOR	ERJ3GEYJ 223 V (22 kΩ)
R235	7030003600	S.RESISTOR	ERJ3GEYJ 223 V (22 kΩ)
R236	7030004040	S.RESISTOR	ERJ3GEYJ 4R7 V (4.7 Ω)
R237	7030003570	S.RESISTOR	ERJ3GEYJ 123 V (12 kΩ)

[MAIN UNIT]

REF NO.	ORDER NO.	DESCRIPTION	
R238	7030003580	S.RESISTOR	ERJ3GEYJ 153 V (15 kΩ)
R239	7030003720	S.RESISTOR	ERJ3GEYJ 224 V (220 kΩ)
R240	7030003640	S.RESISTOR	ERJ3GEYJ 473 V (47 kΩ)
R241	7030003540	S.RESISTOR	ERJ3GEYJ 682 V (6.8 kΩ)
R242	7030003390	S.RESISTOR	ERJ3GEYJ 391 V (390 Ω)
R243	7030004040	S.RESISTOR	ERJ3GEYJ 4R7 V (4.7 Ω)
R244	7030003480	S.RESISTOR	ERJ3GEYJ 222 V (2.2 kΩ)
R245	7030003640	S.RESISTOR	ERJ3GEYJ 473 V (47 kΩ)
R246	7030003640	S.RESISTOR	ERJ3GEYJ 473 V (47 kΩ)
R251	7030003400	S.RESISTOR	ERJ3GEYJ 471 V (470 Ω)
R261	7030003470	S.RESISTOR	ERJ3GEYJ 182 V (1.8 kΩ)
R262	7030003570	S.RESISTOR	ERJ3GEYJ 123 V (12 kΩ)
R263	7030003640	S.RESISTOR	ERJ3GEYJ 473 V (47 kΩ)
R264	7030003550	S.RESISTOR	ERJ3GEYJ 822 V (8.2 kΩ)
R265	7030003560	S.RESISTOR	ERJ3GEYJ 103 V (10 kΩ)
R266	7030003530	S.RESISTOR	ERJ3GEYJ 562 V (5.6 kΩ)
R267	7030003560	S.RESISTOR	ERJ3GEYJ 103 V (10 kΩ)
R269	7030003680	S.RESISTOR	ERJ3GEYJ 104 V (100 kΩ)
R270	7030003580	S.RESISTOR	ERJ3GEYJ 153 V (15 kΩ)
R271	7030003650	S.RESISTOR	ERJ3GEYJ 563 V (56 kΩ)
R272	7030003700	S.RESISTOR	ERJ3GEYJ 154 V (150 kΩ)
R273	7030003440	S.RESISTOR	ERJ3GEYJ 102 V (1 kΩ)
R274	7030003480	S.RESISTOR	ERJ3GEYJ 222 V (2.2 kΩ)
R275	7030003710	S.RESISTOR	ERJ3GEYJ 184 V (180 kΩ)
R276	7030003560	S.RESISTOR	ERJ3GEYJ 103 V (10 kΩ)
R277	7030003750	S.RESISTOR	ERJ3GEYJ 394 V (390 kΩ)
R278	7030010290	S.RESISTOR	ERJ3GEYF 273 V (27 kΩ)
R279	7030004910	S.RESISTOR	ERJ3GEYF 332 V (3.3 kΩ)
R280	7030004730	S.RESISTOR	ERJ3GEYF 222 V (2.2 kΩ)
R281	7030003680	S.RESISTOR	ERJ3GEYJ 104 V (100 kΩ)
R282	7030003680	S.RESISTOR	ERJ3GEYJ 104 V (100 kΩ)
R283	7030003680	S.RESISTOR	ERJ3GEYJ 104 V (100 kΩ)
R284	7030003680	S.RESISTOR	ERJ3GEYJ 104 V (100 kΩ)
R291	7030003660	S.RESISTOR	ERJ3GEYJ 683 V (68 kΩ)
R292	7030003660	S.RESISTOR	ERJ3GEYJ 683 V (68 kΩ)
R293	7030003660	S.RESISTOR	ERJ3GEYJ 683 V (68 kΩ)
R294	7030003560	S.RESISTOR	ERJ3GEYJ 103 V (10 kΩ)
R296	7030003580	S.RESISTOR	ERJ3GEYJ 153 V (15 kΩ)
R297	7030003560	S.RESISTOR	ERJ3GEYJ 103 V (10 kΩ)
R298	7030003520	S.RESISTOR	ERJ3GEYJ 472 V (4.7 kΩ)
R305	7030003680	S.RESISTOR	ERJ3GEYJ 104 V (100 kΩ)
R306	7030003660	S.RESISTOR	ERJ3GEYJ 683 V (68 kΩ)
R307	7030003450	S.RESISTOR	ERJ3GEYJ 122 V (1.2 kΩ)
R311	7030003680	S.RESISTOR	ERJ3GEYJ 104 V (100 kΩ)
R312	7030003680	S.RESISTOR	ERJ3GEYJ 104 V (100 kΩ)
R313	7030003630	S.RESISTOR	ERJ3GEYJ 393 V (39 kΩ)
R314	7030003670	S.RESISTOR	ERJ3GEYJ 823 V (82 kΩ)
R315	7030003750	S.RESISTOR	ERJ3GEYJ 394 V (390 kΩ)
R316	7030003710	S.RESISTOR	ERJ3GEYJ 184 V (180 kΩ)
R317	7030003460	S.RESISTOR	ERJ3GEYJ 152 V (1.5 kΩ)
R321	7030003560	S.RESISTOR	ERJ3GEYJ 103 V (10 kΩ)
R322	7030003520	S.RESISTOR	ERJ3GEYJ 472 V (4.7 kΩ)
R323	7030003560	S.RESISTOR	ERJ3GEYJ 103 V (10 kΩ)
R324	7030003520	S.RESISTOR	ERJ3GEYJ 472 V (4.7 kΩ)
R325	7030003560	S.RESISTOR	ERJ3GEYJ 103 V (10 kΩ)
R326	7030003520	S.RESISTOR	ERJ3GEYJ 472 V (4.7 kΩ)
R336	7030003680	S.RESISTOR	ERJ3GEYJ 104 V (100 kΩ)
R381	7030003560	S.RESISTOR	ERJ3GEYJ 103 V (10 kΩ)
R382	7030003650	S.RESISTOR	ERJ3GEYJ 563 V (56 kΩ)
R383	7030003680	S.RESISTOR	ERJ3GEYJ 104 V (100 kΩ)
R384	7030003590	S.RESISTOR	ERJ3GEYJ 183 V (18 kΩ)
R385	7030003500	S.RESISTOR	ERJ3GEYJ 332 V (3.3 kΩ)
R386	7030003680	S.RESISTOR	ERJ3GEYJ 104 V (100 kΩ)
R387	7030003800	S.RESISTOR	ERJ3GEYJ 105 V (1 MΩ)
R388	7030003440	S.RESISTOR	ERJ3GEYJ 102 V (1 kΩ)
R389	7030003560	S.RESISTOR	ERJ3GEYJ 103 V (10 kΩ)
C1	4030011600	S.CERAMIC	C1608 JB 1E 104K-T
C2	4030011600	S.CERAMIC	C1608 JB 1E 104K-T
C3	4030006860	S.CERAMIC	C1608 JB 1H 102K-T
C4	4030007090	S.CERAMIC	C1608 CH 1H 470J-T
C5	4030011600	S.CERAMIC	C1608 JB 1E 104K-T
C6	4550006560	S.TANTALUM	ECST1CY225R
C7	4030006900	S.CERAMIC	C1608 JB 1H 103K-T
C8	4030007130	S.CERAMIC	C1608 CH 1H 101J-T
C9	4030007000	S.CERAMIC	C1608 CH 1H 090D-T
C10	4030011600	S.CERAMIC	C1608 JB 1E 104K-T
C11	4030007130	S.CERAMIC	C1608 CH 1H 101J-T
C12	4030007130	S.CERAMIC	C1608 CH 1H 101J-T
C13	4030007090	S.CERAMIC	C1608 CH 1H 470J-T
C14	4030006860	S.CERAMIC	C1608 JB 1H 102K-T

S.=Surface mount

[MAIN UNIT]

REF NO.	ORDER NO.	DESCRIPTION
C16	4550006300	S.TANTALUM ECST1AY475R
C17	4550006160	S.TANTALUM ECST1CY155R
C19	4030006860	S.CERAMIC C1608 JB 1H 102K-T
C20	4030006860	S.CERAMIC C1608 JB 1H 102K-T
C21	4030006860	S.CERAMIC C1608 JB 1H 102K-T
C31	4030007040	S.CERAMIC C1608 CH 1H 180J-T
C32	4030007000	S.CERAMIC C1608 CH 1H 090D-T
C33	4030007080	S.CERAMIC C1608 CH 1H 390J-T
C34	4030006860	S.CERAMIC C1608 JB 1H 102K-T
C35	4030011340	S.CERAMIC C1608 CH 1H 471J-T
C36	4030017490	S.CERAMIC C1608 JB 1A 105K-T
C37	4030009540	S.CERAMIC C1608 CH 1H 1R5B-T
C38	4030017490	S.CERAMIC C1608 JB 1A 105K-T
C39	4030009920	S.CERAMIC C1608 CH 1H 050B-T
C40	4030009350	S.CERAMIC C1608 CH 1H 3R5B-T
C41	4030009350	S.CERAMIC C1608 CH 1H 3R5B-T
C42	4030007090	S.CERAMIC C1608 CH 1H 470J-T
C43	4030007020	S.CERAMIC C1608 CH 1H 120J-T
C44	4030011340	S.CERAMIC C1608 CH 1H 471J-T
C45	4030006900	S.CERAMIC C1608 JB 1H 103K-T
C46	4030009560	S.CERAMIC C1608 CH 1H R75B-T
C47	4550006700	S.TANTALUM ECST1AY106R
C48	4550006700	S.TANTALUM ECST1AY106R
C49	4030007050	S.CERAMIC C1608 CH 1H 220J-T
C51	4030009560	S.CERAMIC C1608 CH 1H R75B-T
C52	4030011770	S.CERAMIC C1608 CH 1H 060B-T
C53	4030007050	S.CERAMIC C1608 CH 1H 220J-T
C54	4030007040	S.CERAMIC C1608 CH 1H 180J-T
C55	4030011340	S.CERAMIC C1608 CH 1H 471J-T
C56	4030006900	S.CERAMIC C1608 JB 1H 103K-T
C57	4030009500	S.CERAMIC C1608 CH 1H 0R5B-T
C61	4030006860	S.CERAMIC C1608 JB 1H 102K-T
C62	4030006980	S.CERAMIC C1608 CH 1H 070D-T
C63	4030006860	S.CERAMIC C1608 JB 1H 102K-T
C64	4030011600	S.CERAMIC C1608 JB 1E 104K-T
C65	4030007040	S.CERAMIC C1608 CH 1H 180J-T
C71	4030009520	S.CERAMIC C1608 CH 1H 020B-T
C72	4030006860	S.CERAMIC C1608 JB 1H 102K-T
C73	4030007020	S.CERAMIC C1608 CH 1H 120J-T
C74	4030007100	S.CERAMIC C1608 CH 1H 560J-T
C75	4030007100	S.CERAMIC C1608 CH 1H 560J-T
C81	4030007020	S.CERAMIC C1608 CH 1H 120J-T
C82	4030007020	S.CERAMIC C1608 CH 1H 120J-T
C83	4030007090	S.CERAMIC C1608 CH 1H 470J-T
C91	4030007000	S.CERAMIC C1608 CH 1H 090D-T
C92	4030006860	S.CERAMIC C1608 JB 1H 102K-T
C96	4030006860	S.CERAMIC C1608 JB 1H 102K-T
C97	4030007090	S.CERAMIC C1608 CH 1H 470J-T
C98	4030006860	S.CERAMIC C1608 JB 1H 102K-T
C99	4030006860	S.CERAMIC C1608 JB 1H 102K-T
C103	4030007130	S.CERAMIC C1608 CH 1H 101J-T
C104	4030011600	S.CERAMIC C1608 JB 1E 104K-T
C105	4030006860	S.CERAMIC C1608 JB 1H 102K-T
C106	4030006860	S.CERAMIC C1608 JB 1H 102K-T
C107	4030007050	S.CERAMIC C1608 CH 1H 220J-T
C111	4030007130	S.CERAMIC C1608 CH 1H 101J-T
C112	4030006860	S.CERAMIC C1608 JB 1H 102K-T
C113	4030011600	S.CERAMIC C1608 JB 1E 104K-T
C114	4030007090	S.CERAMIC C1608 CH 1H 470J-T
C115	4030006860	S.CERAMIC C1608 JB 1H 102K-T
C121	4030007100	S.CERAMIC C1608 CH 1H 560J-T
C122	4030006990	S.CERAMIC C1608 CH 1H 080D-T
C123	4030007030	S.CERAMIC C1608 CH 1H 150J-T
C124	4030006860	S.CERAMIC C1608 JB 1H 102K-T
C125	4030007030	S.CERAMIC C1608 CH 1H 150J-T
C126	4030007040	S.CERAMIC C1608 CH 1H 180J-T
C127	4030006860	S.CERAMIC C1608 JB 1H 102K-T
C128	4030007090	S.CERAMIC C1608 CH 1H 470J-T
C129	4030006860	S.CERAMIC C1608 JB 1H 102K-T
C131	4030006860	S.CERAMIC C1608 JB 1H 102K-T
C132	4030007050	S.CERAMIC C1608 CH 1H 220J-T
C133	4030011530	S.CERAMIC C1608 CH 1H 110J-T
C134	4030009650	S.CERAMIC C1608 CH 1H 240J-T
C135	4030006980	S.CERAMIC C1608 CH 1H 070D-T
C136	4030007000	S.CERAMIC C1608 CH 1H 090D-T
C137	4030006860	S.CERAMIC C1608 JB 1H 102K-T
C138	4030009510	S.CERAMIC C1608 CH 1H 010B-T
C141	4030011600	S.CERAMIC C1608 JB 1E 104K-T
C142	4030006860	S.CERAMIC C1608 JB 1H 102K-T
C143	4030011600	S.CERAMIC C1608 JB 1E 104K-T
C144	4030006900	S.CERAMIC C1608 JB 1H 103K-T
C145	4030006860	S.CERAMIC C1608 JB 1H 102K-T

[FRG] only

[MAIN UNIT]

REF NO.	ORDER NO.	DESCRIPTION
C151	4030007000	S.CERAMIC C1608 CH 1H 090D-T
C152	4030007010	S.CERAMIC C1608 CH 1H 100D-T
C153	4030009530	S.CERAMIC C1608 CH 1H 030B-T
C154	4030006860	S.CERAMIC C1608 JB 1H 102K-T
C155	4030006860	S.CERAMIC C1608 JB 1H 102K-T
C156	4030011770	S.CERAMIC C1608 CH 1H 060B-T
C157	4030007060	S.CERAMIC C1608 CH 1H 270J-T
C158	4030006860	S.CERAMIC C1608 JB 1H 102K-T
C159	4030009550	S.CERAMIC C1608 CH 1H 2R5B-T
C160	4030009510	S.CERAMIC C1608 CH 1H 010B-T
C161	4030007100	S.CERAMIC C1608 CH 1H 560J-T
C162	4030006860	S.CERAMIC C1608 JB 1H 102K-T
C163	4030009910	S.CERAMIC C1608 CH 1H 040B-T
C164	4030006980	S.CERAMIC C1608 CH 1H 070D-T
C165	4030006900	S.CERAMIC C1608 JB 1H 103K-T
C166	4030007090	S.CERAMIC C1608 CH 1H 470J-T
C167	4030006900	S.CERAMIC C1608 JB 1H 103K-T
C168	4030011770	S.CERAMIC C1608 CH 1H 060B-T
C171	4030017480	S.CERAMIC C1608 JB 1A 474K-T
C172	4030006860	S.CERAMIC C1608 JB 1H 102K-T
C173	4030007090	S.CERAMIC C1608 CH 1H 470J-T
C181	4030006860	S.CERAMIC C1608 JB 1H 102K-T
C182	4030007120	S.CERAMIC C1608 CH 1H 820J-T
C183	4030006860	S.CERAMIC C1608 JB 1H 102K-T
C184	4030009550	S.CERAMIC C1608 CH 1H 2R5B-T
C185	4030009510	S.CERAMIC C1608 CH 1H 010B-T
C186	4030007070	S.CERAMIC C1608 CH 1H 330J-T
C187	4030006860	S.CERAMIC C1608 JB 1H 102K-T
C188	4030011770	S.CERAMIC C1608 CH 1H 060B-T
C189	4030009920	S.CERAMIC C1608 CH 1H 050B-T
C191	4030006860	S.CERAMIC C1608 JB 1H 102K-T
C192	4030007090	S.CERAMIC C1608 CH 1H 470J-T
C193	4030007100	S.CERAMIC C1608 CH 1H 560J-T
C194	4030008880	S.CERAMIC C1608 JB 1H 223K-T
C195	4030006860	S.CERAMIC C1608 JB 1H 102K-T
C201	4030006860	S.CERAMIC C1608 JB 1H 102K-T
C202	4030007060	S.CERAMIC C1608 CH 1H 270J-T
C203	4030006990	S.CERAMIC C1608 CH 1H 080D-T
C210	4550006300	S.TANTALUM ECST1AY475R
C211	4030006860	S.CERAMIC C1608 JB 1H 102K-T
C213	4030011770	S.CERAMIC C1608 CH 1H 060B-T
C215	4030006860	S.CERAMIC C1608 JB 1H 102K-T
C216	4030006900	S.CERAMIC C1608 JB 1H 103K-T
C217	4030007130	S.CERAMIC C1608 CH 1H 101J-T
C221	4030007010	S.CERAMIC C1608 CH 1H 100D-T
C222	4030006900	S.CERAMIC C1608 JB 1H 103K-T
C223	4030007040	S.CERAMIC C1608 CH 1H 180J-T
C224	4030009520	S.CERAMIC C1608 CH 1H 020B-T
C225	4030007040	S.CERAMIC C1608 CH 1H 180J-T
C226	4030007010	S.CERAMIC C1608 CH 1H 100D-T
C231	4030006860	S.CERAMIC C1608 JB 1H 102K-T
C232	4030007130	S.CERAMIC C1608 CH 1H 101J-T
C233	4030011600	S.CERAMIC C1608 JB 1E 104K-T
C234	4030011600	S.CERAMIC C1608 JB 1E 104K-T
C235	4030011600	S.CERAMIC C1608 JB 1E 104K-T
C236	4030006900	S.CERAMIC C1608 JB 1H 103K-T
C237	4030007140	S.CERAMIC C1608 CH 1H 121J-T
C238	4030007140	S.CERAMIC C1608 CH 1H 121J-T
C239	4550006300	S.TANTALUM ECST1AY475R
C240	4030006860	S.CERAMIC C1608 JB 1H 102K-T
C241	4030011600	S.CERAMIC C1608 JB 1E 104K-T
C242	4030006860	S.CERAMIC C1608 JB 1H 102K-T
C243	4030006860	S.CERAMIC C1608 JB 1H 102K-T
C244	4030006860	S.CERAMIC C1608 JB 1H 102K-T
C245	4030006860	S.CERAMIC C1608 JB 1H 102K-T
C246	4030011340	S.CERAMIC C1608 CH 1H 471J-T
C247	4030006860	S.CERAMIC C1608 JB 1H 102K-T
C251	4030006900	S.CERAMIC C1608 JB 1H 103K-T
C252	4030006900	S.CERAMIC C1608 JB 1H 103K-T
C253	4030006900	S.CERAMIC C1608 JB 1H 103K-T
C261	4030008920	S.CERAMIC C1608 JB 1H 473K-T
C262	4030008900	S.CERAMIC C1608 JB 1H 333K-T
C263	4030008920	S.CERAMIC C1608 JB 1H 473K-T
C265	4030006860	S.CERAMIC C1608 JB 1H 102K-T
C266	4030007150	S.CERAMIC C1608 CH 1H 151J-T
C267	4030006880	S.CERAMIC C1608 JB 1H 472K-T
C268	4030008920	S.CERAMIC C1608 JB 1H 473K-T
C269	4030006900	S.CERAMIC C1608 JB 1H 103K-T
C270	4030017490	S.CERAMIC C1608 JB 1A 105K-T
C271	4550006950	S.TANTALUM ECST0JX476R
C272	4030017480	S.CERAMIC C1608 JB 1A 474K-T
C281	4030006900	S.CERAMIC C1608 JB 1H 103K-T

S.=Surface mount

[MAIN UNIT]

REF NO.	ORDER NO.	DESCRIPTION	
C282	4030006900	S.CERAMIC	C1608 JB 1H 103K-T
C291	4030006900	S.CERAMIC	C1608 JB 1H 103K-T
C292	4030009880	S.CERAMIC	C1608 JB 1H 682K-T
C293	4030008900	S.CERAMIC	C1608 JB 1H 333K-T
C294	4030009970	S.CERAMIC	C1608 JB 1H 182K-T
C301	4030008880	S.CERAMIC	C1608 JB 1H 223K-T
C302	4030006870	S.CERAMIC	C1608 JB 1H 222K-T
C311	4030006860	S.CERAMIC	C1608 JB 1H 102K-T
C312	4030008880	S.CERAMIC	C1608 JB 1H 223K-T
C313	4030009490	S.CERAMIC	C1608 JB 1H 821K-T
C314	4030009490	S.CERAMIC	C1608 JB 1H 821K-T
C315	4030011600	S.CERAMIC	C1608 JB 1E 104K-T
C316	4030008920	S.CERAMIC	C1608 JB 1H 473K-T
C322	4030006900	S.CERAMIC	C1608 JB 1H 103K-T
C323	4030006900	S.CERAMIC	C1608 JB 1H 103K-T
C324	4030006900	S.CERAMIC	C1608 JB 1H 103K-T
C325	4550006710	S.TANTALUM	ECST1AX226R
C326	4550006300	S.TANTALUM	ECST1AY475R
C327	4550006300	S.TANTALUM	ECST1AY475R
C333	4030006860	S.CERAMIC	C1608 JB 1H 102K-T
C341	4030006900	S.CERAMIC	C1608 JB 1H 103K-T
C381	4030017490	S.CERAMIC	C1608 JB 1A 105K-T
C382	4030017490	S.CERAMIC	C1608 JB 1A 105K-T
C383	4030017490	S.CERAMIC	C1608 JB 1A 105K-T
C384	4030011600	S.CERAMIC	C1608 JB 1E 104K-T
C385	4030011600	S.CERAMIC	C1608 JB 1E 104K-T
C386	4030017490	S.CERAMIC	C1608 JB 1A 105K-T
C387	4030017490	S.CERAMIC	C1608 JB 1A 105K-T
C388	4030006900	S.CERAMIC	C1608 JB 1H 103K-T
C389	4030006900	S.CERAMIC	C1608 JB 1H 103K-T
C391	4030011600	S.CERAMIC	C1608 JB 1E 104K-T
C392	4030007060	S.CERAMIC	C1608 CH 1H 270J-T
C393	4030007060	S.CERAMIC	C1608 CH 1H 270J-T
C394	4030007140	S.CERAMIC	C1608 CH 1H 121J-T
C395	4030011600	S.CERAMIC	C1608 JB 1E 104K-T
C396	4030017490	S.CERAMIC	C1608 JB 1A 105K-T
C397	4030017490	S.CERAMIC	C1608 JB 1A 105K-T
C398	4030007020	S.CERAMIC	C1608 CH 1H 120J-T
J281	6510023540	CONNECTOR	B2B-PH-K-S
J351	6510023520	S.CONNECTOR	54104-3692
F281	5210000830	S.FUSE	ERBFE3R00U
W91	7030003860	S.JUMPER	ERJ3GE JPW V
W92	7030003860	S.JUMPER	ERJ3GE JPW V
W101	7030003860	S.JUMPER	ERJ3GE JPW V
W102	7030003860	S.JUMPER	ERJ3GE JPW V
W201	7030003860	S.JUMPER	ERJ3GE JPW V
W202	7030003860	S.JUMPER	ERJ3GE JPW V
EP1	0910055971	PCB	B 5933A
EP2	6910012350	S.BEAD	MMZ1608Y 102BT
EP3	6910012350	S.BEAD	MMZ1608Y 102BT
EP101	6910013370	S.BEAD	BLM18BB221SN1D
EP111	6910014690	S.BEAD	MPZ1608S221A-T

S.=Surface mount

SECTION 7 MECHANICAL PARTS AND DISASSEMBLY

[CHASSIS PARTS]

REF NO.	ORDER NO.	DESCRIPTION	QTY.
J41	6910014700	2600 ANT connector	1
W1	7120000470	Jumper ERDS2T0	1
W2	7120000470	Jumper ERDS2T0	1
W41	8900011880	Cable OPC-1210 (P=0.5 N=36 L=70)	1
MP1	8210019360	2600 front panel Ass'y (A)	1
MP4	8930058380	2600 PTT button	1
MP5	8930058430	2600 PTT plate	1
MP6	8930058360	2600 PTT holder	1
MP7	8950005520	2403 9-PIN connector	1
MP8	8930055890	2403 connector sheet	1
MP9	8930055730	2403 connector seal	1
MP10	8930058720	2600 9-PIN sheet	1
MP11	8930058830	2600 6-Key (A)	1
MP12	8310054570	2600 window plate (A)	1
MP13	8930058730	2600 window sheet	1
MP14	8930039000	1757 sheet	1
MP21	8930059360	2600 release button	1
MP22	8930055760	2403 release plate	1
MP23	8930056540	Spring (AH)	2
MP31	8830001470	VR nut (N)	1
MP32	8930051500	O ring (AB)	1
MP33	8610011220	Knob N294	1
MP35	8810009510	Screw PH BT M2 × 4 NI-ZU	3
MP41	8010019080	2600 chassis	1
MP42	8950005510	2403 contact spring	1
MP43	8930055870	Seal O ring (AO)	1
MP44	8810007890	Screw PH B0 M2 × 4 SUS	1
MP45	8930058550	Seal O ring (AS)	1
MP46	8930058561	Seal 2403 A-main seal-1	1
MP47	8810009510	Screw PH BT M2 × 4 NI-ZU	6
MP51	8830001600	Nut (L)	1
MP52	8810010190	Bind M2 × 4 black SUS	2
MP53	8850001880	Sealing washer (W)	2
MP54	8810010190	Bind M2 × 4 black SUS	1
MP55	8810010120	Screw PH B0 M2 × 8 SUS ZK	2
MP65	8930059830	2600 sheet	1
MP66	8930059800	2600 pet sheet	1
MP71	8210017071	2337 C-panel-1	1
MP72	8810009270	Screw truss M3 × 4 SUS ZK	1
SP1	2510001092	Speaker 036D0801B <KS>	1

[MAIN UNIT]

REF NO.	ORDER NO.	DESCRIPTION	QTY.
MP1	8510015340	2600 PLL plate	1
MP41	8510013000	2336 VCO case Y534	1
MP42	8510011101	1922 VCO cover-1 Y340A	1
MP43	8930060000	2600 shield tape	1
MP101	8510015250	2600 shield case	1
MP111	8410002370	2337 PA heat sink (tip) Y539	1
MP151	8510014860	2600 shield plate	1

[VR UNIT]

REF NO.	ORDER NO.	DESCRIPTION	QTY.
R801	7210003130	TD76N-13F-10KA-2497	1
W801	8900011900	OPC-1192	1
W802	8900012030	OPC-1231	1

Screw abbreviations

B0, BT: Self-tapping PH: Pan head
 NI-ZU: Nickel-Zinc ZK: Black

[ACCESSORIES]

REF NO.	ORDER NO.	DESCRIPTION	QTY.
EP1	Optional products	Antenna FA-S59V	1
EP2	Optional products	AC adaptor BC-147E [EUR, FRG only]	1
EP3	Optional products	Battery BP-227	1
EP4	Optional products	Charger BC-152	1
MP1	Optional products	Hand strap HK-009	1
MP2	Optional products	Swivel belt clip MB-86	1

[LOGIC UNIT]

REF NO.	ORDER NO.	DESCRIPTION	QTY.
MC461	7700002630	Microphone SKB-2246T-C33	1
MP441	6910014760	S. plate OG-503040	1
MP451	6910014760	S. plate OG-503040	1
MP461	8930059810	Microphone rubber 2246	1
MP681	8930058420	2600 LCD holder	1
MP682	8210019110	2600 reflector	1
MP683	8930059700	Himelon sheet (CH)	1
MP684	8930059850	Isolating sheet	1
MP685	8930059850	Isolating sheet	1
DS681	5030002480	LCD L2-0390TAY	1
EP681	8930059150	LCD contact SRCN-2600-SP-N-W	1

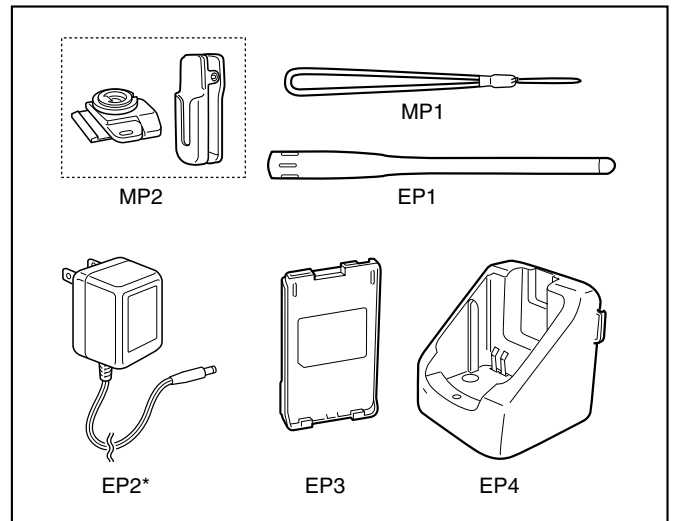

* Design is depended on versions.

• BC-152 CHARGER PARTS LIST
ELECTRICAL PARTS

REF NO.	ORDER NO.	DESCRIPTION	QTY.
IC1	1180000970	S.IC AN78L05M-(E1)	1
IC2	1190001180	S.IC MM1332BFBE	1
IC3	1110005960	S.IC S-80833CNMC-B8S-T2	1
IC4	1190001470	S.IC TB1009AF(EL)	1
IC5	1110002700	S.IC NJM2904M-TE1	1
Q1	1540000550	S.TRANSISTOR 2SD1664 T100Q	1
Q2	1510000500	S.TRANSISTOR 2SA1162-GR (TE85R)	1
Q3	1590002880	S.FET 2SJ417-TL	1
Q4	1520000450	S.TRANSISTOR 2SB1132 T100 Q	1
Q5	1590000700	S.TRANSISTOR DTC144EKA T146	1
Q6	1590000930	S.TRANSISTOR DTA144EKA T146	1
D1	1790000670	S.DIODE SB07-03C-TB	1
D2	1730002540	S.ZENER MA8130-L(TX)	1
D3	1750000150	S.DIODE DA204K T146	1
D4	1730002460	S.ZENER MA8330-M(TX)	1
D5	1750000550	S.DIODE 1SS355 TE-17	1
D6	1160000070	S.DIODE DAN202K T146	1
D7	1730002320	S.ZENER MA8051-M(TX)	1
R1	7030000380	S.RESISTOR MCR10EZHZ 1 kΩ(102)	1
R2	7030000140	S.RESISTOR MCR10EZHZ 10 Ω (100)	1
R3	7030000140	S.RESISTOR MCR10EZHZ 10 Ω (100)	1
R4	7030000450	S.RESISTOR MCR10EZHZ 3.9kΩ (392)	1
R5	7030000450	S.RESISTOR MCR10EZHZ 3.9kΩ (392)	1
R6	7030000500	S.RESISTOR MCR10EZHZ 10 kΩ (103)	1
R7	7030002920	S.RESISTOR MCR10EZHF 39 kΩ (393)	1
R8	7030000580	S.RESISTOR MCR10EZHZ 47 kΩ (473)	1
R9	7030000420	S.RESISTOR MCR10EZHZ 2.2kΩ (222)	1
R10	7030000260	S.RESISTOR MCR10EZHZ 100 Ω (101)	1
R11	7030000500	S.RESISTOR MCR10EZHZ 10 kΩ (103)	1
R12	7030000530	S.RESISTOR MCR10EZHZ 18 kΩ (183)	1
R13	7030001780	S.RESISTOR MCR10EZHF 18 kΩ (183)	1
R14	7030000500	S.RESISTOR MCR10EZHZ 10 kΩ (103)	1
R15	7030000500	S.RESISTOR MCR10EZHZ 10 kΩ (103)	1
R16	7030000540	S.RESISTOR MCR10EZHZ 22 kΩ (223)	1
R17	7030010150	S.RESISTOR MCR10EZHF 2943 (294kΩ)	1
R19	7030000530	S.RESISTOR MCR10EZHZ 18 kΩ (183)	1
R20	7030000300	S.RESISTOR MCR10EZHZ 220 Ω (221)	1
R21	7030000500	S.RESISTOR MCR10EZHZ 10 kΩ (103)	1
R22	7030000540	S.RESISTOR MCR10EZHZ 22 kΩ (223)	1
R23	7030000550	S.RESISTOR MCR10EZHZ 27 kΩ (273)	1
R24	7030000020	S.RESISTOR MCR10EZHZ 1 Ω (010)	1
R25	7030000020	S.RESISTOR MCR10EZHZ 1 Ω (010)	1
R27	7030000580	S.RESISTOR MCR10EZHZ 47 kΩ (473)	1
R28	7030000500	S.RESISTOR MCR10EZHZ 10 kΩ (103)	1
R29	7030000680	S.RESISTOR MCR10EZHZ 330 kΩ (334)	1
R30	7030000510	S.RESISTOR MCR10EZHZ 12 kΩ (123)	1
C1	4030004750	S.CERAMIC C2012 JB 1H 103K-T	1
C2	4510005340	ELECTROL 25 MV 47 HC	1
C3	4030008960	S.CERAMIC C2012 JB 1C 104K-T	1
C4	4030004720	S.CERAMIC C2012 JB 1H 102K-T	1
C5	4030004720	S.CERAMIC C2012 JB 1H 102K-T	1
C6	4510006160	ELECTROL 25 MV 10 HC	1
C7	4030008960	S.CERAMIC C2012 JB 1C 104K-T	1
C8	4030008960	S.CERAMIC C2012 JB 1C 104K-T	1
C9	4510006160	ELECTROL 25 MV 10 HC	1
C10	4030008960	S.CERAMIC C2012 JB 1C 104K-T	1
C11	4030008660	S.CERAMIC C2012 JB 1H 333K-T	1
C12	4030008960	S.CERAMIC C2012 JB 1C 104K-T	1
C13	4510006160	ELECTROL 25 MV 10 HC	1
C14	4030008960	S.CERAMIC C2012 JB 1C 104K-T	1
C15	4030008960	S.CERAMIC C2012 JB 1C 104K-T	1
J1	6510023070	CONNECTOR HEC2305-01-250	1
DS1	5040001390	LED TLG124A	1

REF NO.	ORDER NO.	DESCRIPTION	QTY.
W1	7030000010	S.JUMPER MCR10EZHZ JPW (000)	1
W2	7030000010	S.JUMPER MCR10EZHZ JPW (000)	1
W3	7030000010	S.JUMPER MCR10EZHZ JPW (000)	1
W4	7030000010	S.JUMPER MCR10EZHZ JPW (000)	1
EP1	910055642	PCB B 5894B	1

MECHANICAL PARTS
CHASSIS PARTS (C)

REF NO.	ORDER NO.	DESCRIPTION	QTY.
MP1	8010019100	Case 2612	1
MP4	8110007810	Cover 2612	1
MP5	8810008660	Screw BT M3 × 8 NI-ZU	3
MP6	8930039620	LEG cushion (A)	2

CHARGER PARTS (CH)

REF NO.	ORDER NO.	DESCRIPTION	QTY.
MP1	8930051341	2338 TERMINAL-1	1
MP2	8930051341	2338 TERMINAL-1	1
MP3	8930051341	2338 TERMINAL-1	1
MP4	8930051341	2338 TERMINAL-1	1

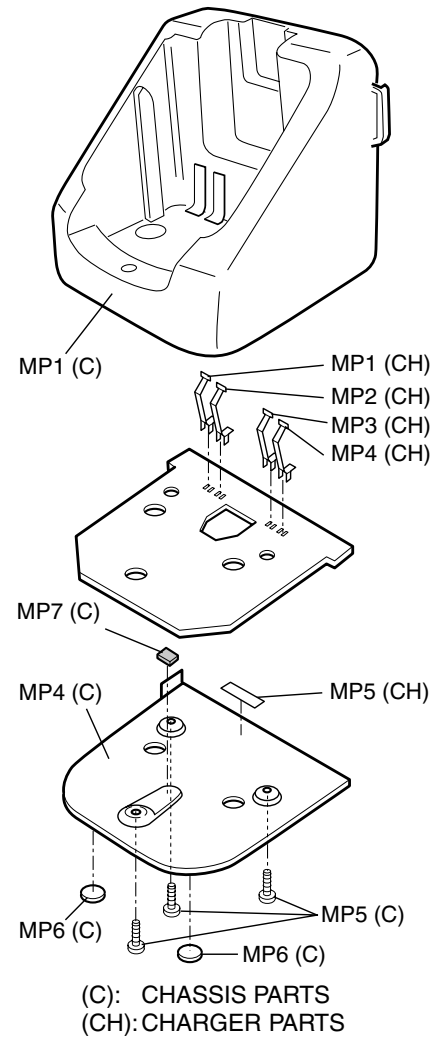

ACCESSORY PARTS

REF NO.	ORDER NO.	DESCRIPTION	QTY.
MP1	8810001470	Screw.5 × 30 SUS	2

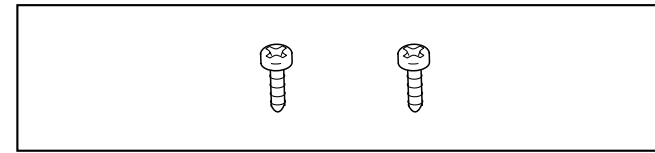

• BC-152 VOLTAGE DIAGRAM

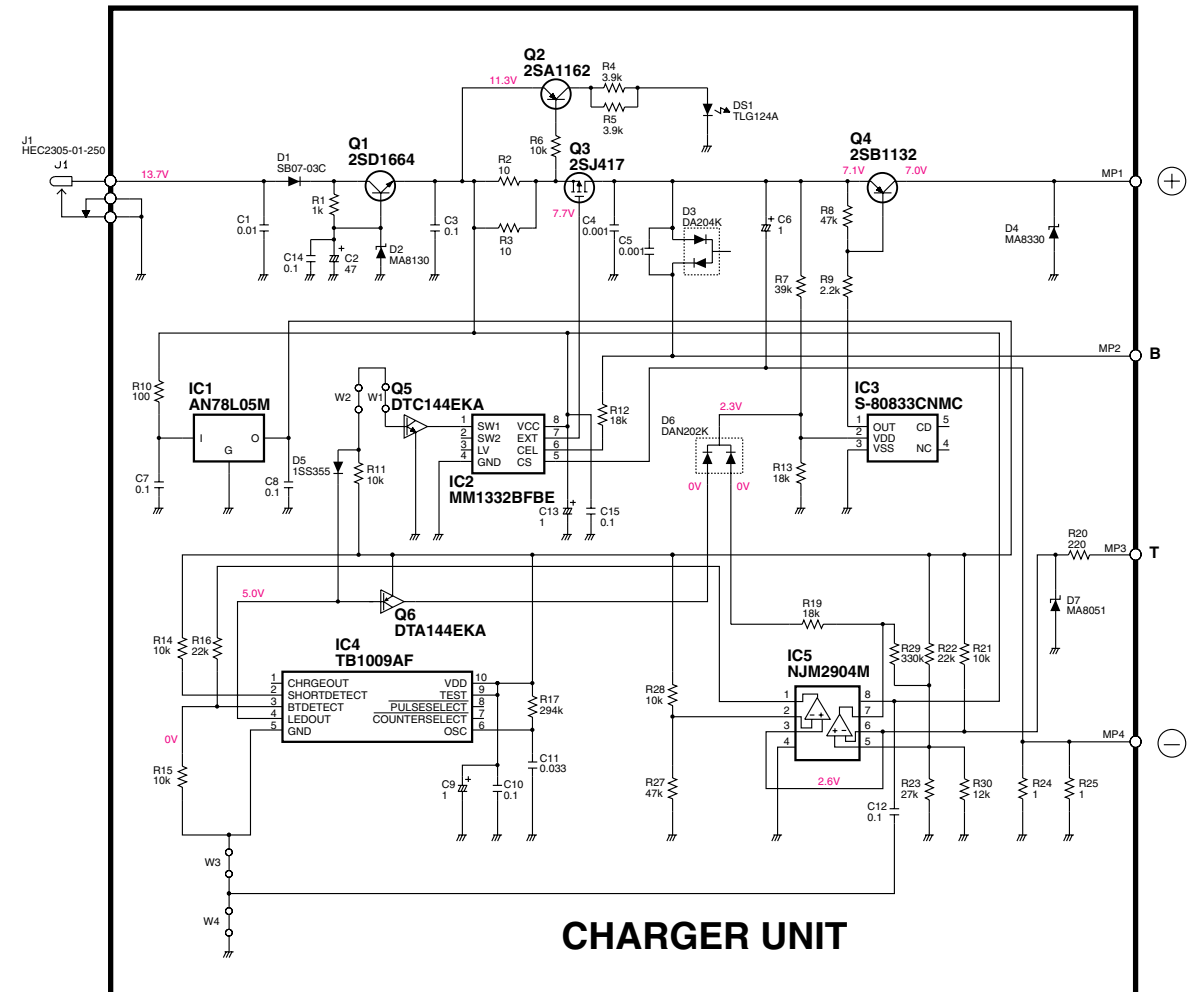

SECTION 8 SEMI-CONDUCTOR INFORMATION

8 - 1 TRANSISTORS AND FETS

• MAIN unit and LOGIC unit

2SA1588-GR (Symbol: ZG) 	2SB1132 T100 Q (Symbol: BAQ) 	2SC4116 BL/GR (Symbol: LL/LG) 	2SC4213-B (Symbol: AB) 	2SC4215 O/Y (Symbol: QO/QY)
2SC4226-T1 R25 (Symbol: R25) 	2SC5107 O (Symbol: MFO) 	2SC5110-O (TE85R) (Symbol: MGO) 	2SK1829(TE85R) (Symbol: KI) 	2SK880Y (Symbol: XY)
3SK294 (Symbol: UV) 	3SK299-T1 U73 (Symbol: U73) 	CPH3403-TL (Symbol: KC) 	DTA144EUA T106 (Symbol: 16) 	DTC144EUA (Symbol: 26)
RD01MUS1 (Symbol: K2) 	RD07MVS1 (Symbol: RD07MVS1) 	UN911F/H (Symbol: 6O/6P) 	XP1213(TX) (Symbol: 9L) 	XP1214(TX) (Symbol: 9H)
XP4601(TX) (Symbol: 5C) 	XP6501 AB (Symbol: 5N) 			

• CHARGER unit

2SA1162-GR (Symbol: SG) 	2SD1664 T100Q (Symbol: DAQ) 	2SJ417-TL (Symbol: J417) 	DTA144EKA T146 (Symbol: 16) 	DTC144EKA T146 (Symbol: 26)
--------------------------------	------------------------------------	---------------------------------	------------------------------------	------------------------------------

8 - 2 DIODES

• MAIN unit and LOGIC unit

1SS375-TL (Symbol: FH) 	1SV245 (Symbol: T3) 	1SV307 (TPH3) (Symbol: TX) 	DAN222TL (Symbol: N-4) 	HVC350BTRF (Symbol: B0)
HVC362TRF (Symbol: V2) 	HVU350B TRF (Symbol: 4) 	MA2S111 (Symbol: A) 	MA2S728-(TX) (Symbol: B) 	MA77(TX) (Symbol: 4B)
MA8056-M (Symbol: 5-6) 	MA8062-M(TX) (Symbol: 6-2) 	RB706F-40T106 (Symbol: 3J) 		

• CHARGER unit

1SS355 TE-17 (Symbol: A) 	DA204K T146 (Symbol: K) 	DAN202K T146 (Symbol: N) 	MA8051-M (Symbol: 5-1) 	MA8130-L (Symbol: 13_)
MA8330-M (Symbol: 33-) 	SB07-03C-TB (Symbol: 12) 			

SECTION 9 BOARD LAYOUTS

9 - 1 CHARGER UNIT (BC-152)

• TOP VIEW

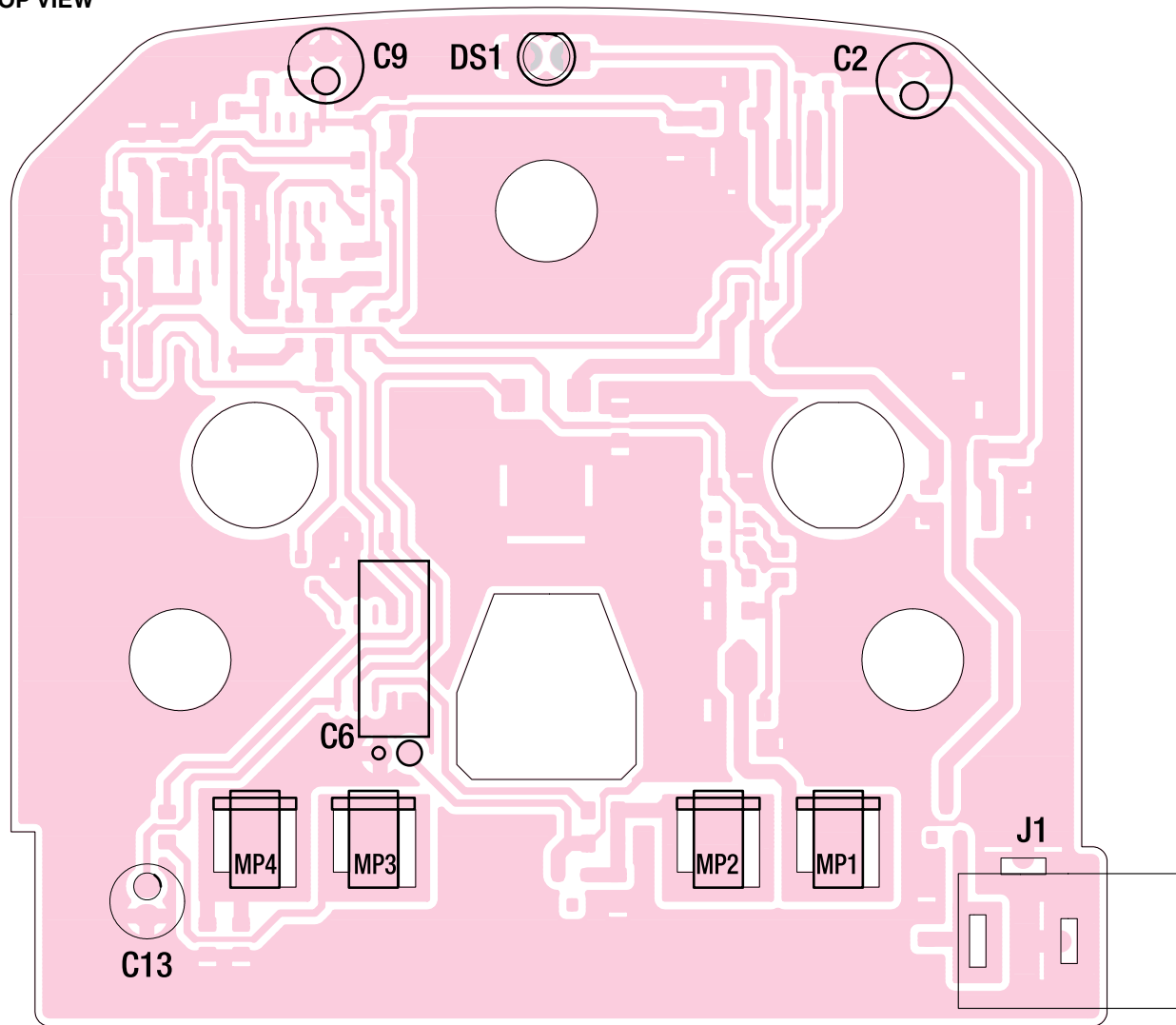

• BOTTOM VIEW

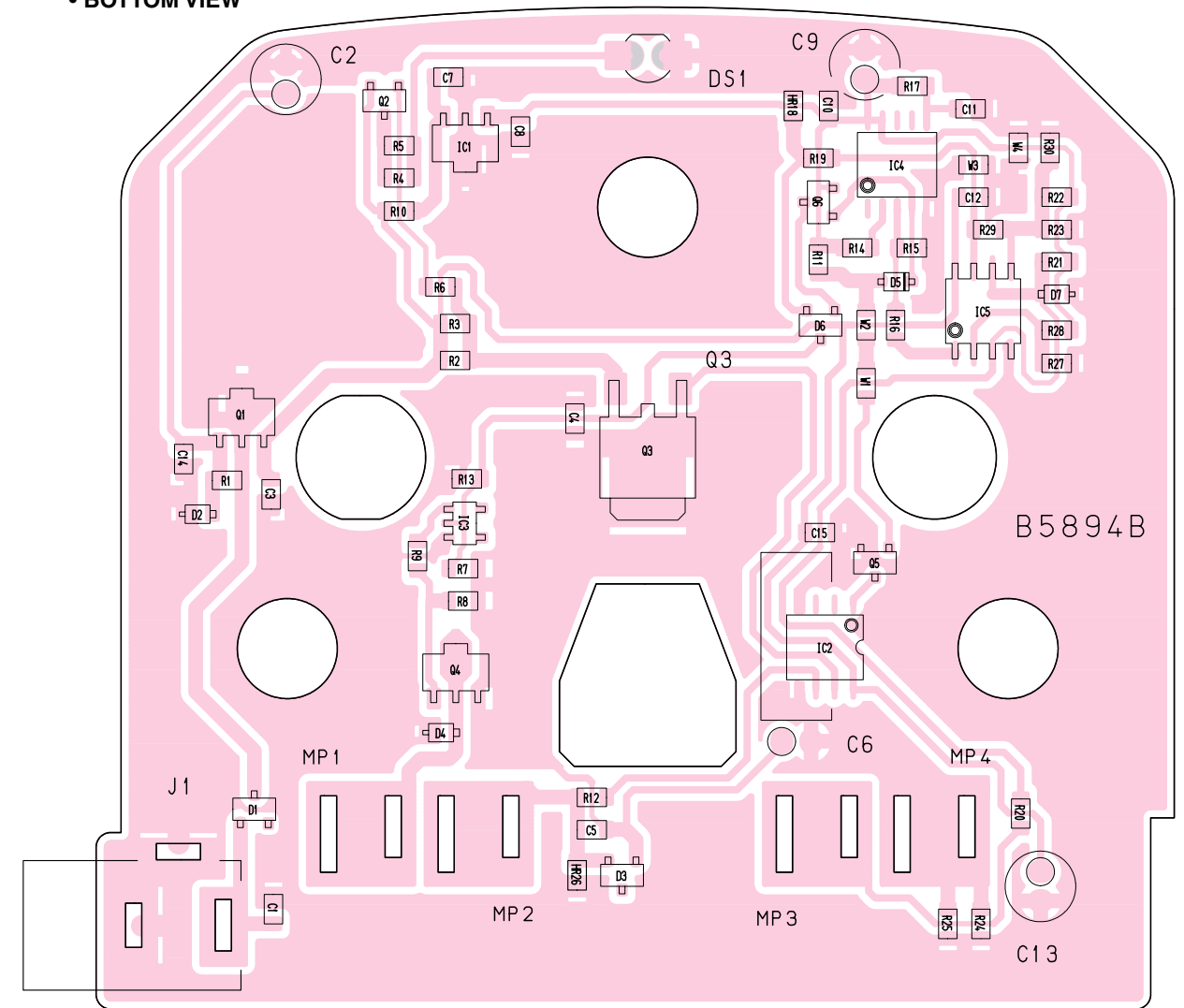

9-2 VR UNIT

• TOP VIEW

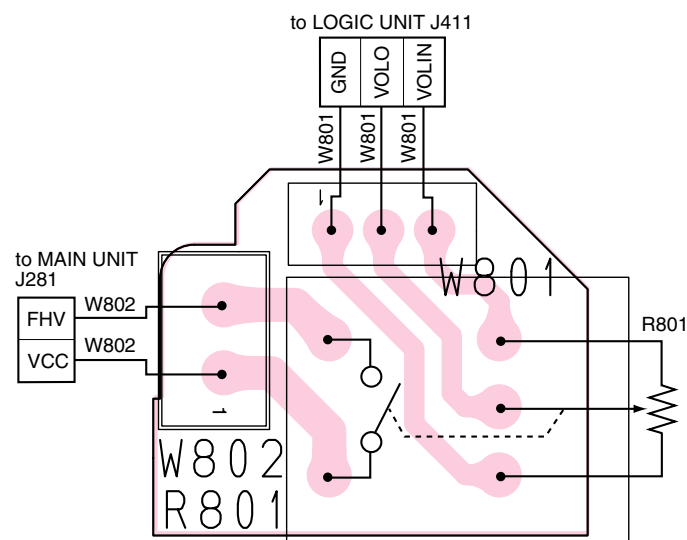

• BOTTOM VIEW

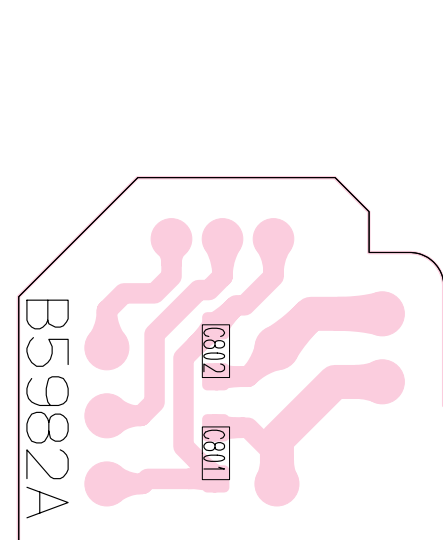

9-3 CONNECTOR UNIT

• TOP VIEW

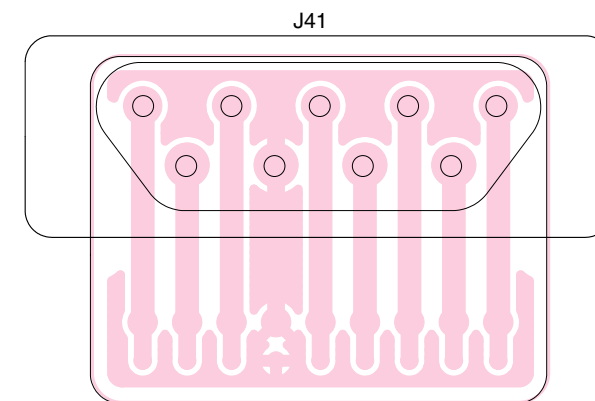

• BOTTOM VIEW

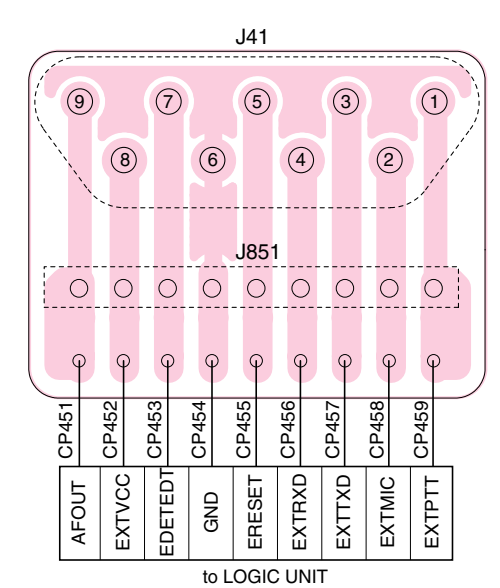

9-4 MAIN UNIT

• TOP VIEW

The combination of this page and the next page shows the unit layout in the same configuration as the actual P.C. Board.

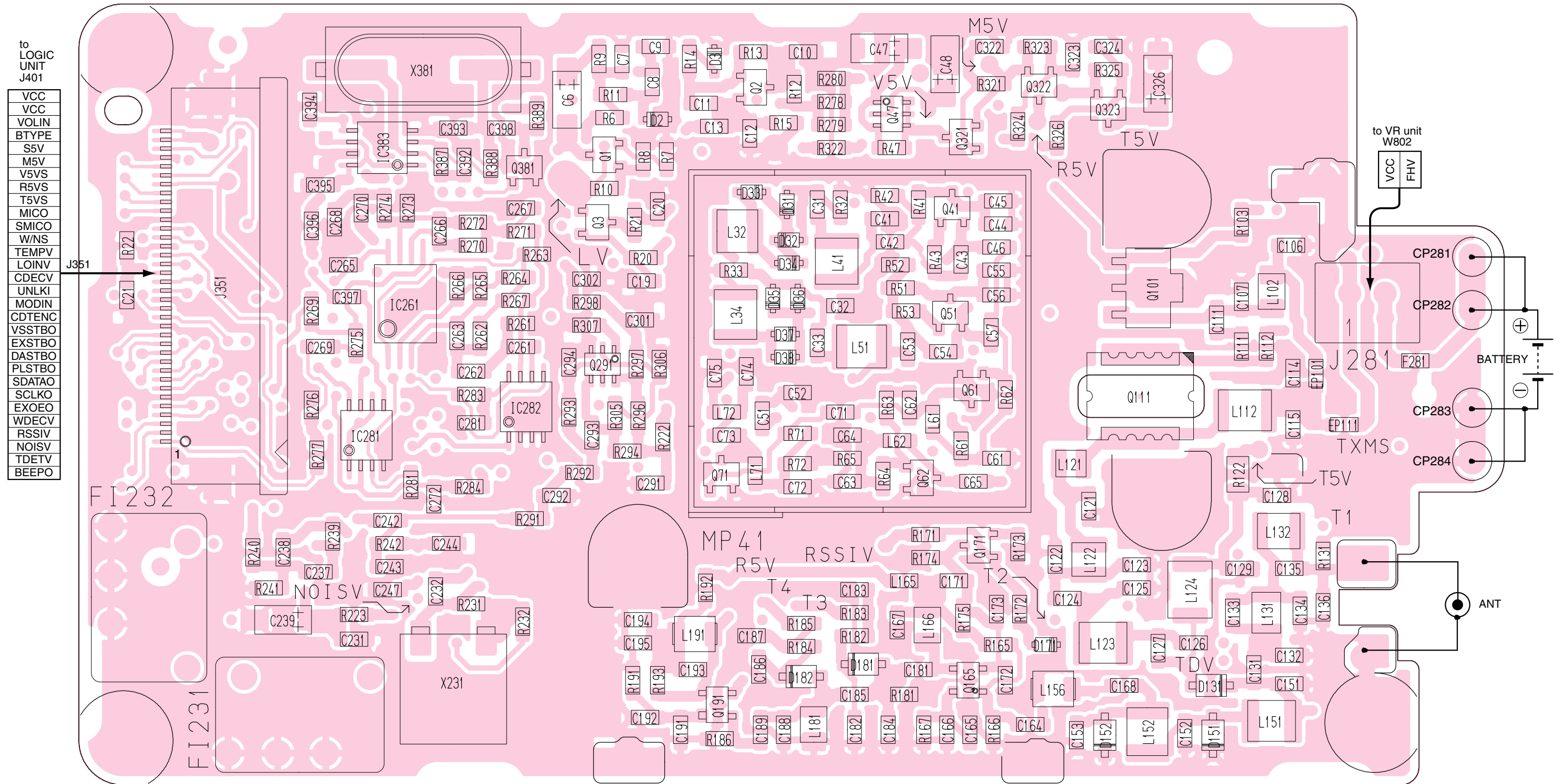

MAIN UNIT
• **BOTTOM VIEW**

The combination of this page and the previous page shows the unit layout in the same configuration as the actual P.C. Board.

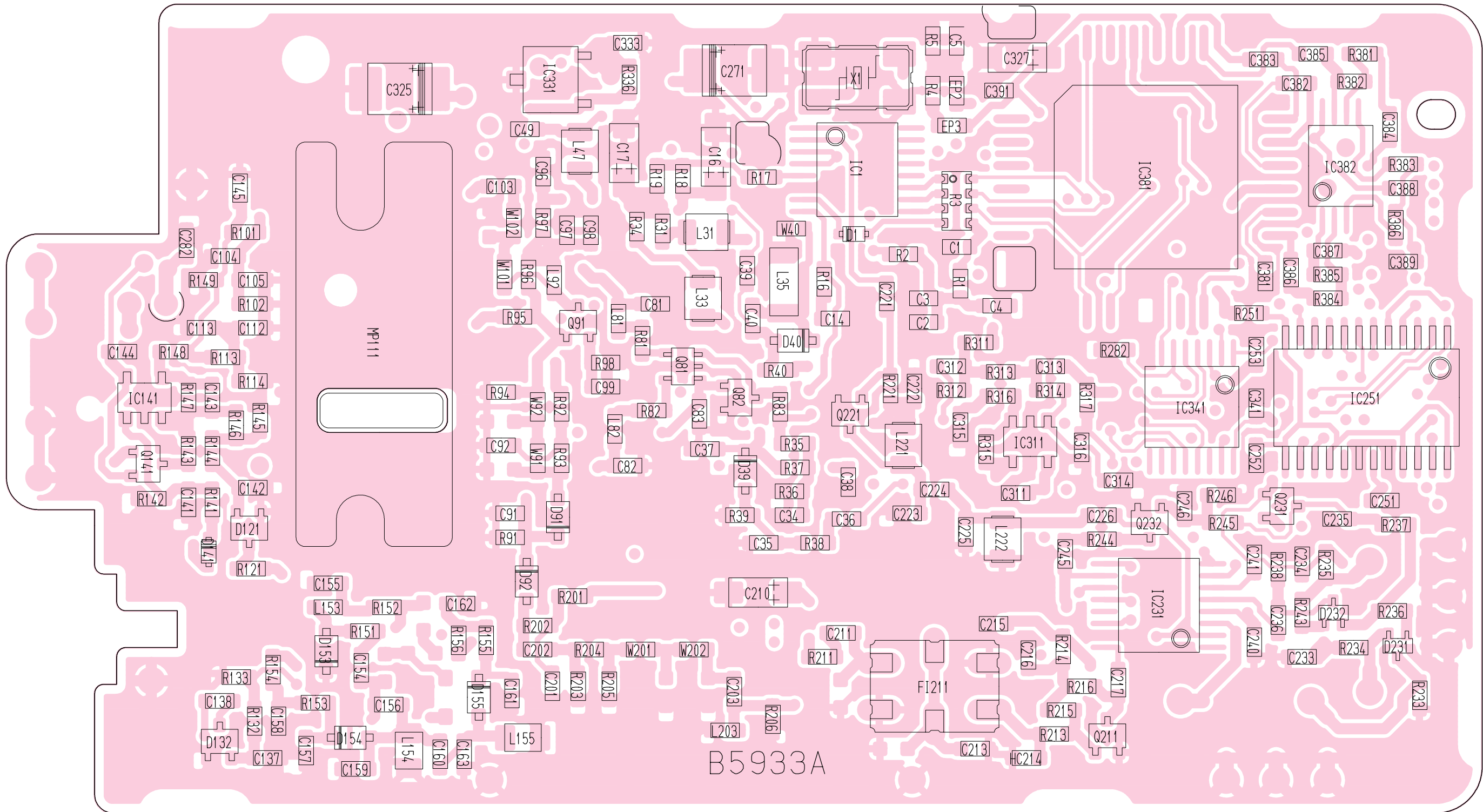

LOGIC UNIT
• BOTTOM VIEW

The combination of this page and the previous page shows the unit layout in the same configuration as the actual P.C. Board.

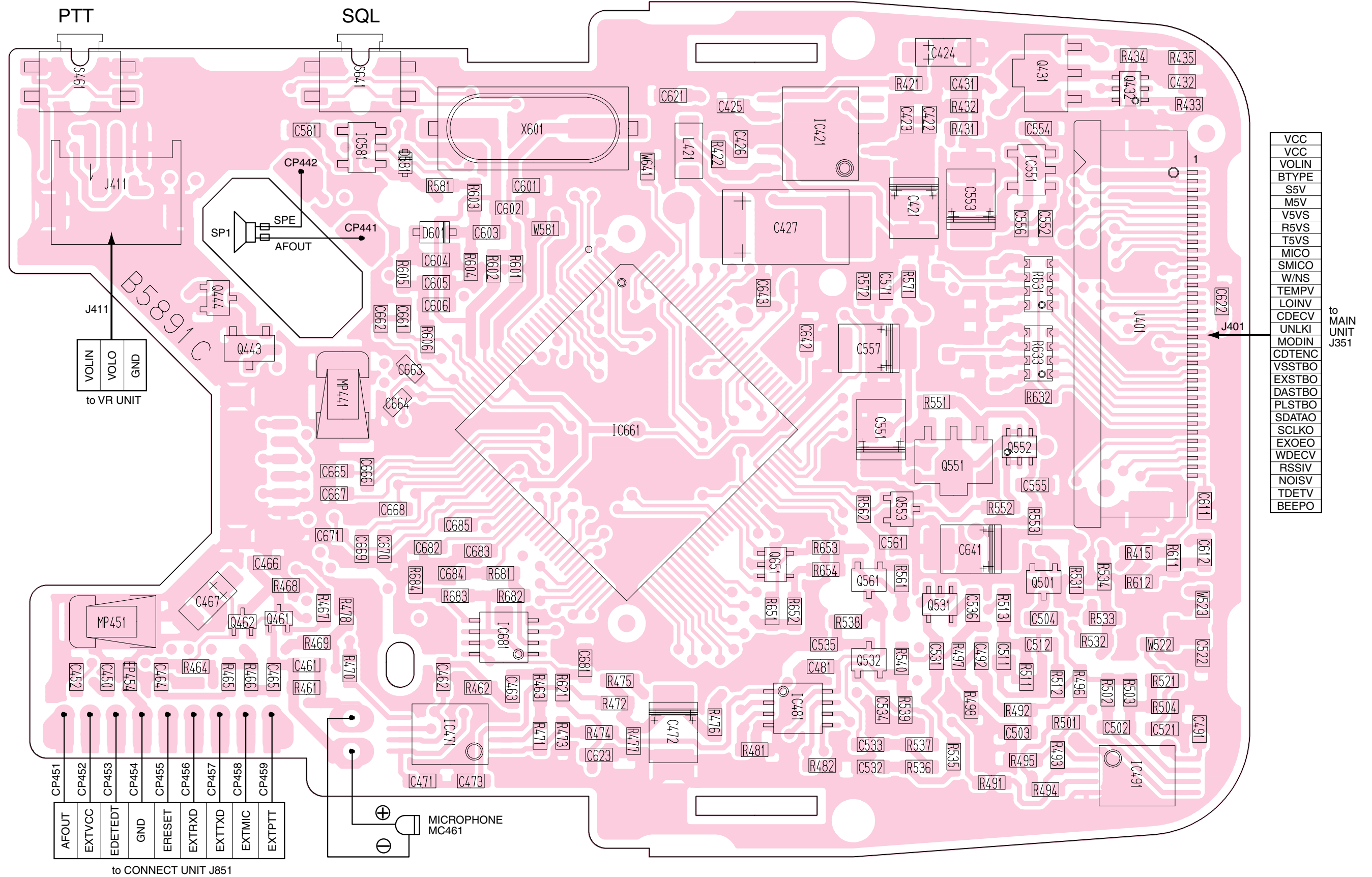

VCC
VCC
VOLIN
BTYPE
S5V
M5V
V5VS
R5VS
T5VS
MICO
SMICO
W/NS
TEMPV
LOINV
CDECV
UNLKI
MODIN
CDTENC
VSSTBO
EXSTBO
DASTBO
PLSTBO
SDATAO
SCLKO
EXOEV
WDECV
RSSIV
NOISV
TDETV
BEEPO

to MAIN UNIT J351

CP451	CP452	CP453	CP454	CP455	CP456	CP457	CP458	CP459
AFOUT	EXTVCC	EDETEDT	GND	ERESSET	EXTRXD	EXTTXD	EXTMIC	EXTPPT

to CONNECT UNIT J851

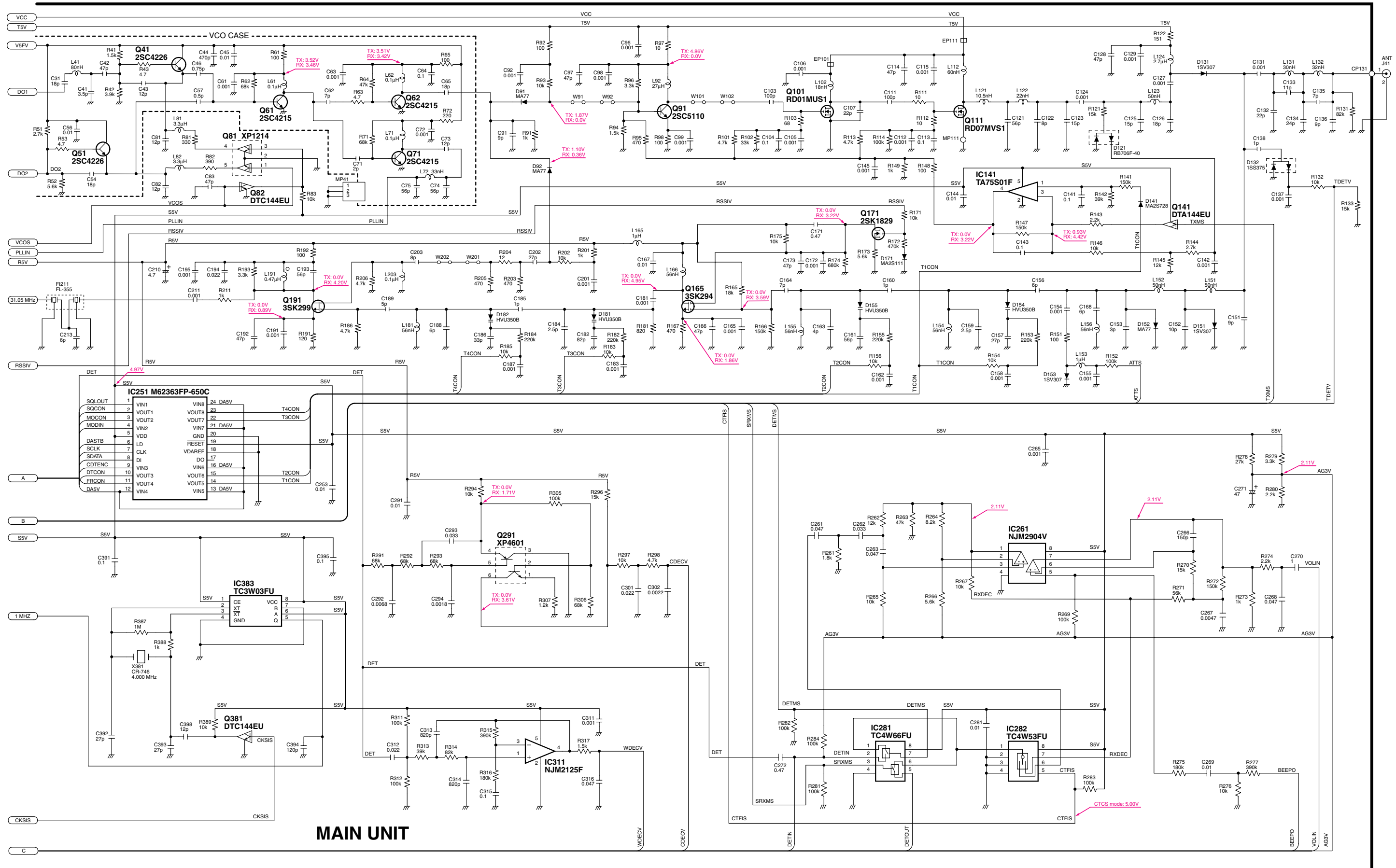

MAIN UNIT

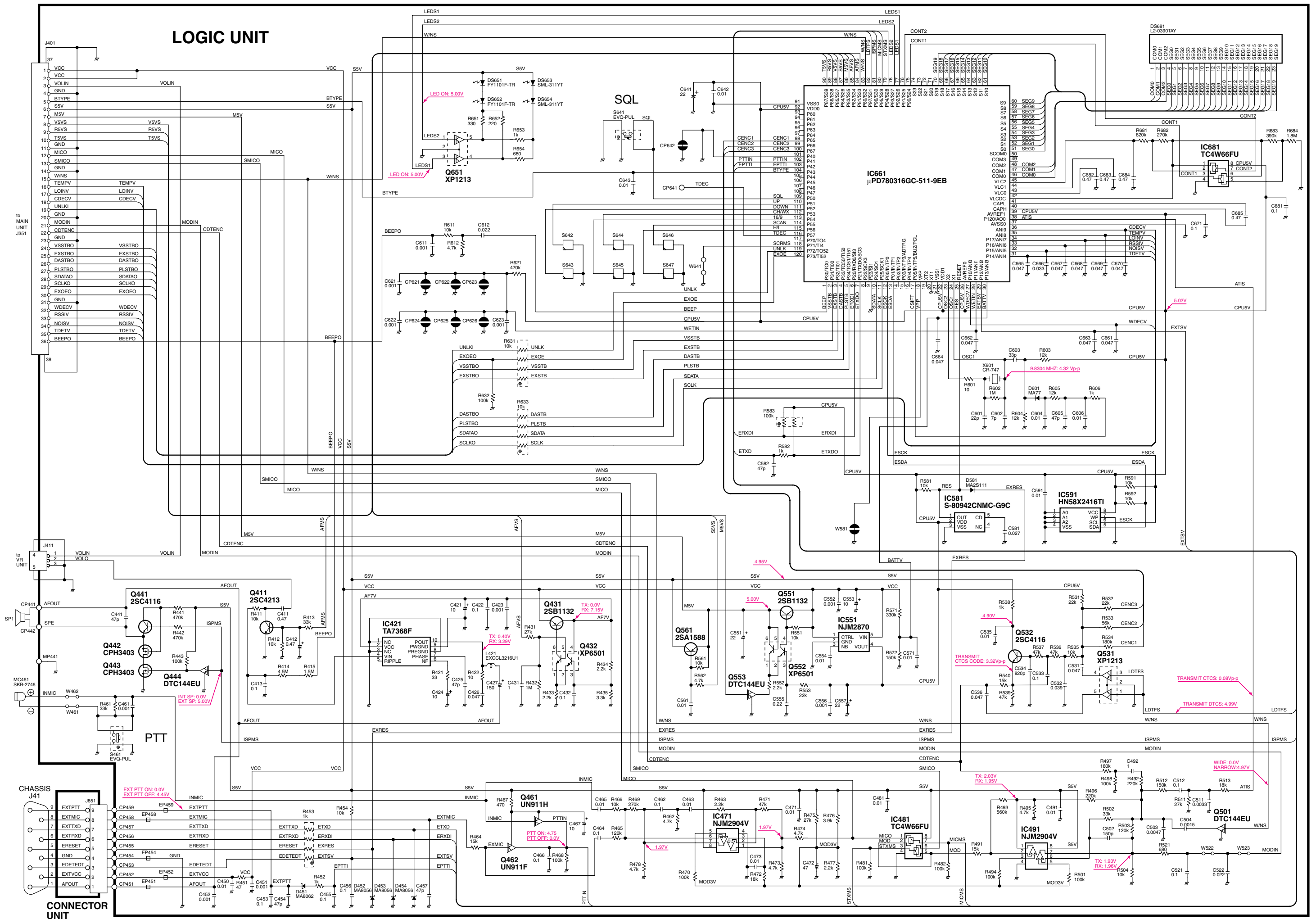

LOGIC UNIT

SQL

**IC661
µPD780316GC-511-9EB**

**IC681
TC4W66FU**

Icom Inc.

1-1-32, Kamiminami, Hirano-ku, Osaka 547-0003, Japan
Phone : +81 (06) 6793 5302
Fax : +81 (06) 6793 0013
URL : <http://www.icom.co.jp/world/index.html>

Icom America Inc.

<Corporate Headquarters>
2380 116th Avenue N.E., Bellevue, WA 98004, U.S.A.
Phone : +1 (425) 454-8155 Fax : +1 (425) 454-1509
URL : <http://www.icomamerica.com>
<Customer Service>
Phone : +1 (425) 454-7619

Icom Canada

Glenwood Centre #150-6165
Highway 17 Delta, B.C., V4K 5B8, Canada
Phone : +1 (604) 952-4266 Fax : +1 (604) 952-0090
URL : <http://www.icomcanada.com>

Icom (Australia) Pty. Ltd.

A.B.N. 88 006 092 575
290-294 Albert Street, Brunswick, Victoria, 3056, Australia
Phone : +61 (03) 9387 0666 Fax : +61 (03) 9387 0022
URL : <http://www.icom.net.au>

Icom New Zealand

146A Harris Road, East Tamaki,
Auckland, New Zealand
Phone : +64 (09) 274 4062 Fax : +64 (09) 274 4708
URL : <http://www.icom.co.nz>

Beijing Icom Ltd.

1305, Wanshang Plaza, Shijingshan Road, Beijing China
Phone : +86 (010) 6866 6337 Fax : +86 (010) 6866 3553
URL : <http://www.bjicom.com>

Icom (Europe) GmbH

Communication Equipment
Himmelgeister Str. 100, D-40225 Düsseldorf, Germany
Phone : +49 (0211) 346047 Fax : +49 (0211) 333639
URL : <http://www.icomeurope.com>

Icom Spain S.L

Crta. de Gracia a Manresa Km. 14,750
08190 Sant Cugat del Valles Barcelona, SPAIN
Phone : +34 (93) 590 26 70 Fax : +34 (93) 589 04 46
URL : <http://www.icomspain.com>

Icom (UK) Ltd.

Unit 9, Sea St., Herne Bay, Kent, CT6 8LD, U.K.
Phone : +44 (01227) 741741 Fax : +44 (01227) 741742
URL : <http://www.icomuk.co.uk>

Icom France S.a

Zac de la Plaine, 1, Rue Brindejone des Moulinais
BP 5804, 31505 Toulouse Cedex, France
Phone : +33 (5) 61 36 03 03 Fax : +33 (5) 61 36 03 00
URL : <http://www.icom-france.com>

Asia Icom Inc.

6F No. 68, Sec. 1 Cheng-Teh Road, Taipei, Taiwan, R.O.C.
Phone : +886 (02) 2559 1899 Fax : +886 (02) 2559 1874
URL : <http://www.asia-icom.com>

Count on us!