



SERVICE MANUAL

CLASS D/DSC TERMINAL

DS-100

INTRODUCTION

This service manual describes the latest service information for the **DS-100** CLASS D/DSC TERMINAL at the time of publication

To upgrade quality, any electrical or mechanical parts and internal circuits are subject to change without notice or obligation.

DANGER

NEVER connect the terminal unit to an AC outlet or to a DC power supply that uses more than 16 V. This will ruin the terminal unit.

DO NOT expose the terminal unit to rain, snow or any liquids.

DO NOT reverse the polarities of the power supply when connecting the terminal unit.

DO NOT apply an RF signal of more than 20 dBm (100 mW) to the antenna connector. This could damage the terminal unit's front end.



ORDERING PARTS

Be sure to include the following four points when ordering replacement parts:

1. 10-digit order numbers
2. Component part number and name
3. Equipment model name and unit name
4. Quantity required

<SAMPLE ORDER>

1110003200 S.IC TA31136FN DS-100 MAIN UNIT 5 pieces
8810006050 Screw Icom screw E7 DS-100 Rear panel 10 pieces
Addresses are provided on the inside back cover for your convenience.

REPAIR NOTES

1. Make sure a problem is internal before disassembling the terminal unit.
2. **DO NOT** open the terminal unit until the terminal unit is disconnected from its power source.
3. **DO NOT** force any of the variable components. Turn them slowly and smoothly.
4. **DO NOT** short any circuits or electronic parts. An insulated tuning tool **MUST** be used for all adjustments.
5. **DO NOT** keep power ON for a long time when the terminal unit is defective.
6. **READ** the instructions of test equipment thoroughly before connecting equipment to the terminal unit.

TABLE OF CONTENTS

SECTION 1 SPECIFICATIONS

SECTION 2 INSIDE VIEWS

SECTION 3 CIRCUIT DESCRIPTION

3 - 1	RECEIVER CIRCUITS	3 - 1
3 - 2	PLL CIRCUIT	3 - 2
3 - 3	DSC CIRCUIT	3 - 2
3 - 4	NMEA AND DATA INTERFACE CIRCUITS	3 - 2
3 - 5	POWER SUPPLY CIRCUIT	3 - 2
3 - 6	LOGIC CIRCUIT	3 - 2
3 - 7	PORT ALLOCATIONS	3 - 2

SECTION 4 ADJUSTMENT PROCEDURES

4 - 1	PREPARATION	4 - 1
4 - 2	REFERENCE AND RECEIVER ADJUSTMENTS	4 - 2

SECTION 5 PARTS LIST

SECTION 6 MECHANICAL PARTS

SECTION 7 SEMI-CONDUCTOR INFORMATION

SECTION 8 BOARD LAYOUTS

8 - 1	LOGIC UNIT	8 - 1
8 - 2	MAIN UNIT	8 - 3

SECTION 9 BLOCK DIAGRAM

SECTION 10 VOLTAGE DIAGRAM

10 - 1	LOGIC UNIT	10 - 1
10 - 2	MAIN UNIT	10 - 2

SECTION 1 SPECIFICATIONS

■ GENERAL

- Frequency coverage : 156.525 MHz (Ch 70) Rx only
- Mode : 16K0G2B
- Power supply requirement : 13.8 V DC (negative ground)
- Usable temperature range : -20°C to +60°C
- Current drain (at 13.8 V DC) : 1.0 A (approx.)
- Antenna impedance : 50 Ω (nominal)
- Output impedance (for testing) : 100 k Ω (nominal)
- Dimensions (projections not included) : 165(W) \times 110(H) \times 78(D) mm
- Weight : 1 kg (approx.)

■ RECEIVER

- Receive system : Double conversion superheterodyne system
- Intermediate frequencies : 1st 21.7 MHz
2nd 450 kHz
- Sensitivity : -10 dB μ typical at 12 dB SINAD
- Adjacent channel selectivity : 70 dB
- Spurious response : 70 dB
- Intermodulation rejection ratio : 68 dB
- Hum and noise : -40 dB

Specifications are measured in accordance with EN301-025.

All stated specifications are subject to change without notice or obligation.

SECTION 2 INSIDE VIEWS

• MAIN UNIT

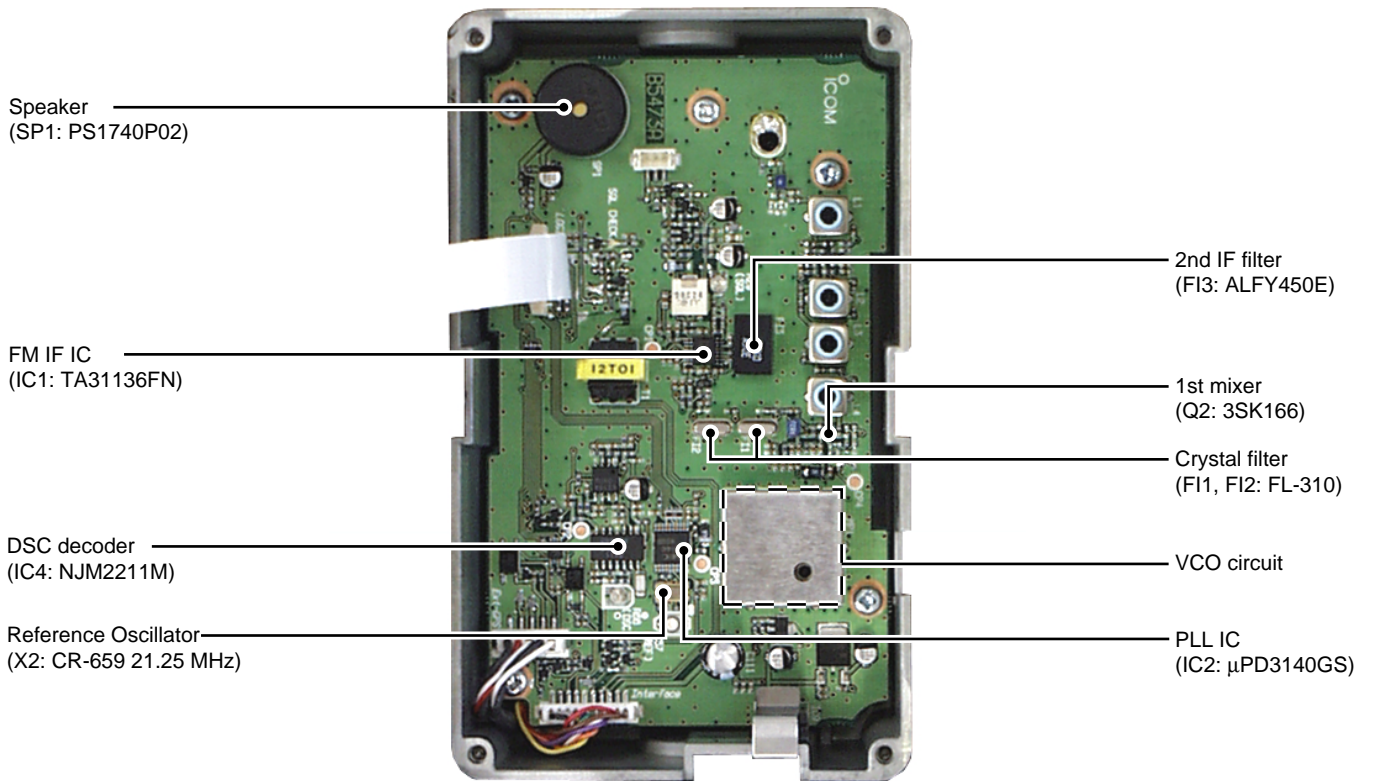

• LOGIC UNIT

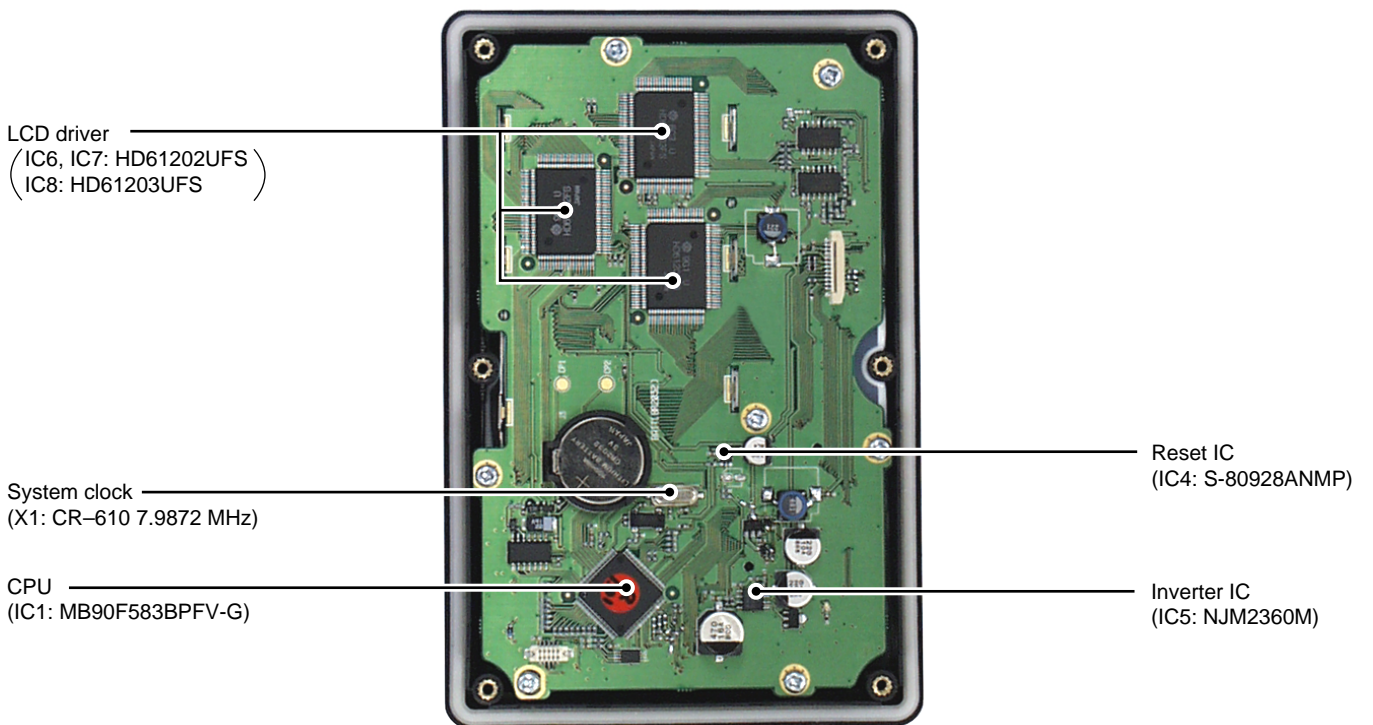

SECTION 3 CIRCUIT DESCRIPTION

3-1 RECEIVER CIRCUITS

3-1-1 RF AMPLIFIER CIRCUIT (MAIN UNIT)

The RF circuit amplifies signals within the range of frequency coverage and filters out-of-band signals.

The signals from the antenna connector are amplified at the RF amplifier (Q1) via the bandpass filter (L1, C3). The amplified signals are applied to the 1st mixer circuit (Q2) after out-of-band signals are suppressed at the 3-stage of bandpass filters (L2, L3, L4, C11, C14, C17).

3-1-2 1ST MIXER AND 1ST IF CIRCUITS (MAIN UNIT)

The 1st mixer circuit converts the received signal into a fixed frequency of the 1st IF signal with a PLL output frequency. By changing the PLL frequency, only the desired frequency will pass through a crystal filter at the next stage of the 1st mixer.

The signals from the RF circuit are mixed at the 1st mixer (Q2) with a 1st LO signal coming from the PLL circuit to produce a 21.7 MHz 1st IF signal.

The 1st IF signal is applied to the crystal filters (F11, F12) to suppress out-of-band signals. The filtered 1st IF signal is amplified at the 1st IF amplifier (Q3), then applied to the 2nd mixer circuit (IC1, pin 16).

3-1-3 2ND IF AND DEMODULATOR CIRCUITS (MAIN UNIT)

The 2nd mixer circuit converts the 1st IF signal into a 2nd IF signal. A double conversion superheterodyne system (which converts receive signals twice) improves the image rejection ratio and obtains stable receiver gain.

The 1st IF signal from the IF amplifier is applied to the 2nd mixer section of the FM IF IC (IC1, pin 16), and is mixed with the 2nd LO signal to be converted into a 450 kHz 2nd IF signal.

The FM IF IC contains the 2nd mixer, limiter amplifier, quadrature detector and active filter circuits. A 2nd LO signal (21.25 MHz) is produced at the PLL circuit using reference frequency.

The 2nd IF signal from the 2nd mixer (IC1, pin 3) passes through ceramic filter (F13) to remove unwanted heterodyned frequencies. It is then amplified at the limiter amplifier (IC1, pin 5), and is applied to the quadrature detector (IC1, pins 10, 11) to demodulate the 2nd IF signal into AF signals.

3-1-4 SQUELCH CIRCUIT (MAIN UNIT)

A portion of the AF signals from the FM IF IC (IC1, pin 9) is applied to the active filter section (IC1, pin 8) where noise components are amplified and detected with an internal noise detector. The squelch level adjustment pot (R29) is connected to the active filter input (pin 8) to control the input noise level.

The active filter section amplifies noise components. The filtered signals are rectified at the noise detector section and converted into "SQL" signal (DC voltage) at the noise comparator section. The "SQL" signal is output from pin 13.

This squelch circuit is only used for the BUSY detection of Ch70, and is not related the DSC decoder sensitivity and etc.

•2nd IF and demodulator circuits

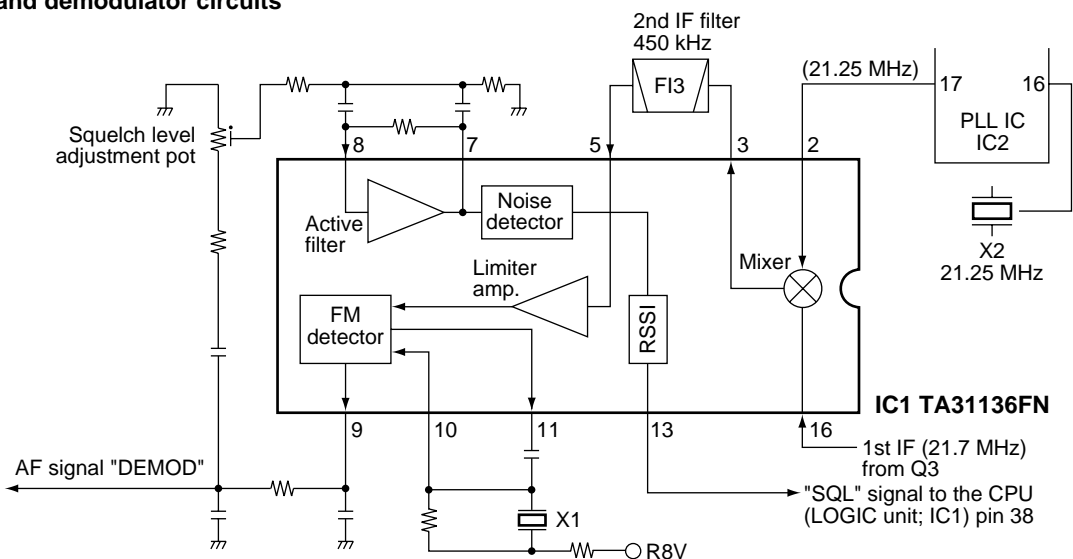

3-2 PLL CIRCUIT

3-2-1 PLL CIRCUIT (MAIN UNIT)

A PLL circuit provides stable oscillation of the receiver 1st LO frequency. The PLL output compares the phase of the divided VCO frequency to the reference frequency. The PLL output frequency is controlled by the divided ratio (N-data) of a programmable divider.

The PLL IC (IC2) contains a prescaler, programmable counter, programmable divider phase detector, charge pump and etc. The entered signal is divided at the prescaler and programmable counter section by the N-data ratio from the CPU. The divided signal is detected on phase at the phase detector using the reference frequency (21.25 MHz).

If the oscillated signal drifts, its phase changes from that of the reference frequency, causing a lock voltage change to compensate for the drift in the oscillated frequency.

3-3 DSC CIRCUITS

3-3-1 DSC DECODE CIRCUIT (MAIN UNIT)

The AF signals from FM IF IC (IC1, pin 9) are filtered at the bandpass filter (IC3) with +18 dB/octave characteristics to remove except 1300 Hz and 2100 Hz signals. The filtered signals are converted analog signals into digital signals at IC4, and are then applied to the CPU after shaping waveform at IC6.

3-3-2 DSC ENCODE CIRCUIT (MAIN UNIT)

The DSC signals from the D/A outputs of CPU are amplified at the buffer amplifier (Q17) and converted into 600 Ω impedance at T1. The signals are output to the connected transceiver as floating system output.

• PLL circuit

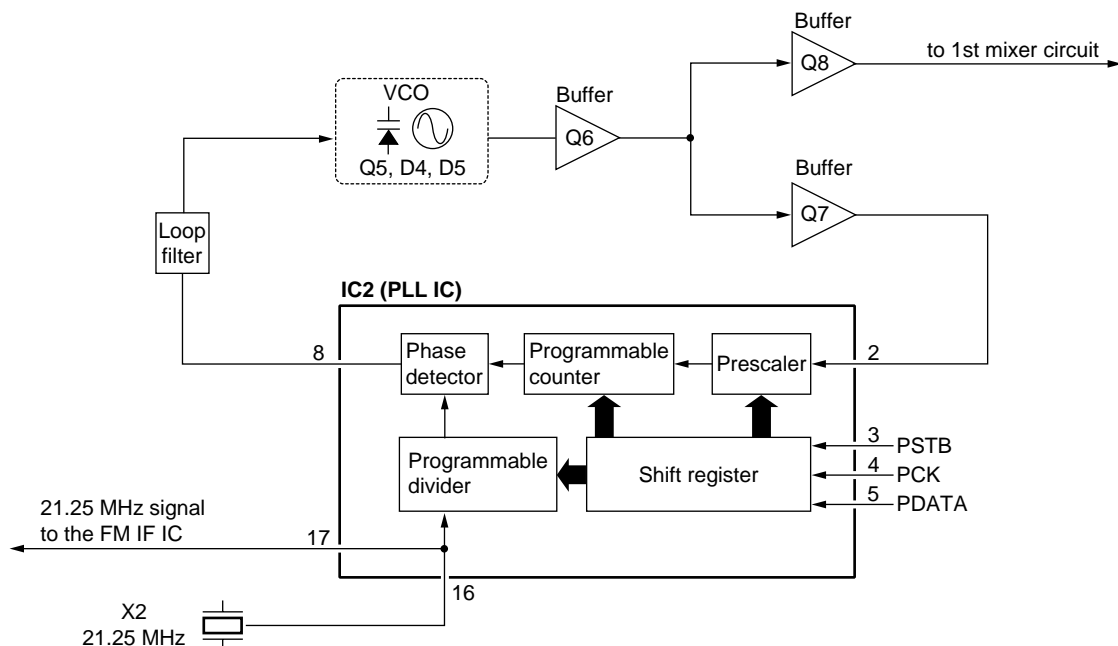

3-4 NMEA AND DATA INTERFACE CIRCUITS

3-4-1 NMEA CIRCUIT (MAIN UNIT)

The NMEA signals (GGA) from OPC-945 are applied to IC5 and are shaped waveform at IC6, and are then applied to the CPU.

3-4-2 DATA INTERFACE CIRCUIT (MAIN UNIT)

The control signals from the connected transceiver with OPC-951 are applied to IC8 and are shaped wave form at IC6, and are then applied to the CPU.

3-5 POWER SUPPLY CIRCUITS

3-5-1 VOLTAGE LINE (MAIN UNIT)

LINE	DESCRIPTION
13.8 V	The voltage from the connected transceiver.
8 V	Common 8 V converted from the 13.8 V line and regulated by the 8 V regulator circuit (IC9).
5 V	Common 5 V converted from the 8 V line and regulated by the 5 V regulator circuit (IC10).
R8V	8 V for receiver circuits regulated by the R8V regulator circuit (Q15, Q16).

3-6 LOGIC CIRCUITS (LOGIC UNIT)

• CPU

IC1 is 16 bit single chip microcomputer and contains serial I/O, timer, A/D converter, D/A converter, programmable I/O, ROM and RAM.

• SYSTEM CLOCK CIRCUIT

X1 is a high-stability crystal oscillator and oscillated a 7.9872 MHz system clock for the CPU (IC1).

• RESET CIRCUIT

IC4 is a reset IC. When turn power ON, IC4 outputs a reset signal ("LOW" pulse) to CPU (IC1, pin 75).

• LCD DRIVER

IC6–IC8 are LCD driver for a dot matrix LCD.

• INVERTER CIRCUIT

IC4 is a –8V DC-DC converter IC and converts –8 V from the HV line. The converted voltage (–8V) is used for driving the LCD.

• CLOCK CIRCUIT

IC3 is a clock IC and also used for backup the position/time information for DSC.

• DIMMER CIRCUIT

Q2, Q3, Q6 are dimmer circuit and control the LCD backlight (LED).

3-7 PORT ALLOCATIONS

3-7-1 CPU (LOGIC UNIT)

Pin number	Port name	Description
1–7	KEY-3–KEY-9	Input port for the [3]–[9] keys.
8	KEY-0	Input port for the [0] key.
10	KEY-L	Input port for the [LEFT] key.
11	KEY-U	Input port for the [UP] key.
12	KEY-D	Input port for the [DOWN] key.
13	KEY-R	Input port for the [RIGHT] key.
14	KEY-A	Input port for the [A/a] key.
15	KEY-BS	Input port for the [BS] key.
19	CLR X	Input port for the cloning data from the buffer (MAIN unit; D8).
20	CLTX	Output port for the cloning data to the buffer (MAIN unit; Q9).
23	ECK	Outputs clock signal for EEPROM (IC2).
24	EDA	Outputs serial data signal for EEPROM (IC2).
26	RCEV	Outputs the R8V regulator circuit (MAIN unit; Q15, Q16) control signal. High : While receiving
30	DSMOD	D/A output port for the DSC encode signal to the buffer amplifier (MAIN unit; Q17).

Pin number	Port name	Description
31	CADJ	Outputs control signal for the LCD contrast.
36	NMEAI	Input port for serial signal from the NMEA connector (MAIN unit; J1) via the photo coupler (MAIN unit; IC5) and buffer amplifier (MAIN unit; IC6).
37	NMEAO	Outputs serial signal to the NMEA connector (MAIN unit; J1) via the buffer amplifier (Q13, Q14, D11).
38	SQL	Input port for noise level signal (DC voltage) for squelch operation.
41–44	DIM0–DIM3	Output LCD backlight control signals for the dimmer circuit (Q2, Q3, Q6).
45	DDEC	Input port for the DSC decode signal. Low : DSC signal is decoded.
46	UNLK	Input port for the PLL unlock signal. Low : While PLL is locked.
52, 53	CS1, CS2	Outputs chip select signal for the LCD drivers (IC6–IC8).
54, 55, 56	RW, DI, E	Output control signals for the LCD driver (IC6–IC8).
57	DATAS	Input port for the control signal from IC-M501EURO via the photo coupler (MAIN unit; IC8) and buffer amplifier (MAIN unit; IC6).
58	DATAM	Outputs the control signal to IC-M501EURO via the Buffer amplifier (MAIN unit; Q11, Q12, D10).
60	BUSY	Outputs busy LED (MAIN unit; DS1) control signal.
65	KEY-ENT	Input port for the [ENT] key.
66	KEY-CLR	Input port for the [CLR] key.
67	KEY-CAL	Input port for the [CALL] key.
68	KEY-DTR	Input port for the [DISTRESS] key.
69	BEEP	Outputs beep audio signal.
73	CCS	Outputs chip select signal for the clock IC (IC3).
74	PSTB	Outputs strobe signals for the PLL circuit.
83–90	DB0–DB7	Output data signals for the LCD driver (IC6–IC8).
96	SCK	Outputs clock signal to the clock IC (IC3).
97	SO	Outputs serial signal for the clock IC (IC3).
98	SI	Input port for serial signal from the clock IC (IC3).
99, 100	KEY-1, KEY-2	Input port for the [1], [2] keys.

SECTION 4 ADJUSTMENT PROCEDURES

4-1 PREPARATION

■ REQUIRED TEST EQUIPMENT

EQUIPMENT	GRADE AND RANGE	EQUIPMENT	GRADE AND RANGE
DC power supply	Output voltage : 13.8 V DC	Digital multimeter	Measuring range : 10 mV–10 V
	Current capacity : 2 A or more	DC voltmeter	Input impedance : 50 k Ω /V DC or better
Frequency counter	Frequency range : 0.1–300 MHz	AC millivoltmeter	Measuring range : 10 mV–10 V
	Frequency accuracy: ± 1 ppm or better	Oscilloscope	Frequency range : DC–20 MHz
Sensitivity : 100 mV or better	Measuring range : 0.01–20 V		
Standard signal generator (SSG)	Frequency range : 0.1–300 MHz	External speaker	Input impedance : 4 Ω
	Output level : 0.1 μ V–32 mV (–127 to –17 dBm)		Capacity : 5 W or more
Distortion meter	Frequency range : 1 kHz ± 10 %	Terminator	Impedance : 100 k Ω
	Measuring range : 1–100 %		

■ CONNECTIONS

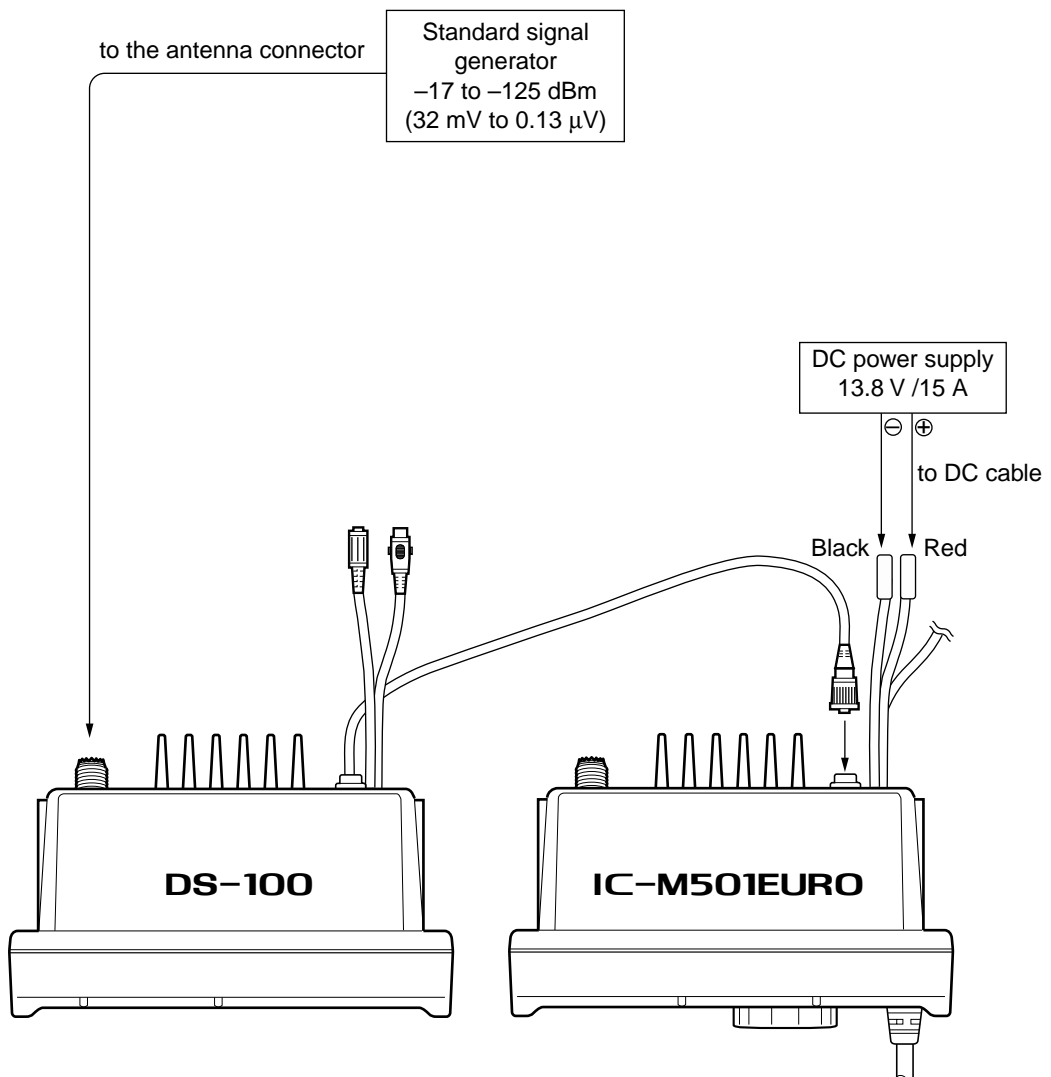

4-2 REFERENCE AND RECEIVER ADJUSTMENTS

ADJUSTMENT		ADJUSTMENT CONDITION	MEASUREMENT		VALUE	ADJUSTMENT POINT	
			UNIT	LOCATION		UNIT	ADJUST
LOCK VOLTAGE	1	<ul style="list-style-type: none"> Receiving 	MAIN	Connect a digital multi-meter or oscilloscope to check point CP3.	2.1 V	MAIN	L9
REFERENCE FREQUENCY	1	<ul style="list-style-type: none"> Receiving 	MAIN	Connect a frequency counter to check point CP4.	134.825000 MHz	MAIN	C57
SENSITIVITY	1	<ul style="list-style-type: none"> Connect an distortion meter with an 100 kΩ dummy load to the external speaker jack J4 on MAIN unit. Connect an SSG to the antenna connector and set as: <ul style="list-style-type: none"> Frequency : 156.525 MHz Level : 10 μV* (-97 dBm) Modulation : 1 kHz Deviation : \pm3.0 kHz Receiving 	MAIN	Connect a digital multi-meter or oscilloscope to check point CP1.	Maximum voltage	MAIN	L1, L2, L3, L4
SQUELCH	1	<ul style="list-style-type: none"> Turn R29 counter clockwise on the MAIN unit to 9 o'clock position. Connect an SSG to the antenna connector and set as: <ul style="list-style-type: none"> Frequency : 156.525 MHz Level : 0.25 μV* (-119 dBm) Modulation : 1 kHz Deviation : \pm3.0 kHz Receiving 	MAIN	DS1	At the point where the check point DS1 just turns OFF.	MAIN	Turn R29 to clockwise.

*This output level of a standard signal generator (SSG) is indicated as SSG's open circuit.

• MAIN unit

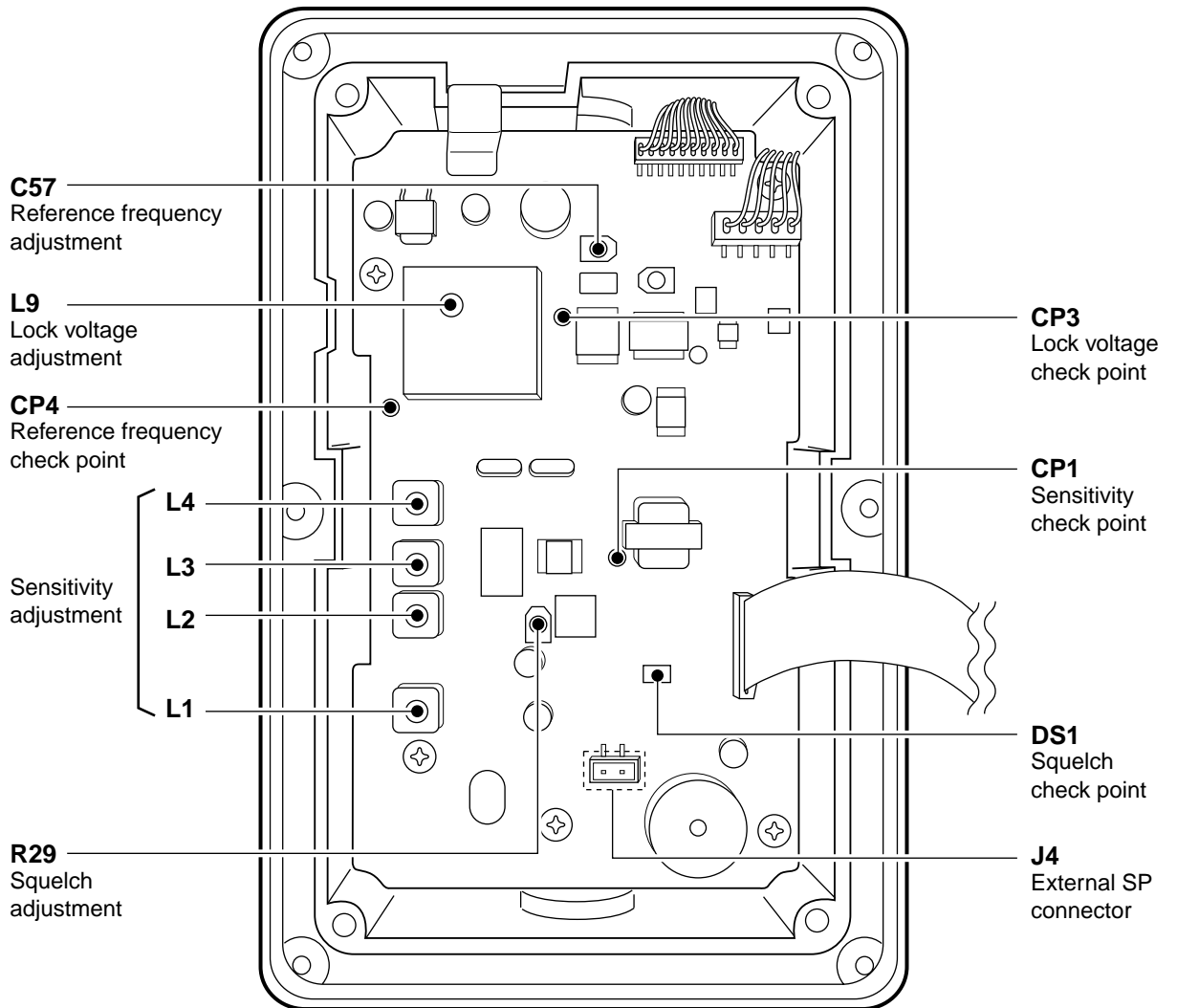

SECTION 5 PARTS LIST

[LOGIC UNIT]

REF NO.	ORDER NO.	DESCRIPTION	
IC1	1140008940	S.IC	MB90F583BPFV-G
IC2	1130009680	S.IC	HN58X2432TI
IC3	1130007450	S.IC	RTC-4553A
IC4	1110004710	S.IC	S-80928ANMP-DDR-T2
IC5	1110004200	S.IC	NJM2360M-TE3
IC6	1130008850	S.IC	HD61202UFS
IC7	1130008850	S.IC	HD61202UFS
IC8	1130008860	S.IC	HD61203UFS
IC9	1110003870	S.IC	NJM2058M-T1
IC10	1110003870	S.IC	NJM2058M-T1
Q2	1530002850	S.TRANSISTOR	2SC4116-BL (TE85R)
Q3	1520000460	S.TRANSISTOR	2SB1132 T100 R
Q4	1510000580	S.TRANSISTOR	2SA1362-GR (TE85R)
Q5	1590000420	S.TRANSISTOR	RN1404 (TE85R)
Q6	1530002850	S.TRANSISTOR	2SC4116-BL (TE85R)
D1	1720000360	S.DIODE	HSU88TRF
D2	1750000020	S.DIODE	1SS184 (TE85R)
D3	1790001470	S.DIODE	SB10-05PCP-TD
D4	1790001010	S.ZENER	MA8043-L (TX)
X1	6050010290	S.XTAL	CR-610 (7.9872 MHz)
X2	6050011030	S.XTAL	DMX-26S 32.768KHZ
L1	6200009370	S.COIL	SLF7032T-221MR29-2
L2	6200008880	S.COIL	SLF7032T-681MR16-2
R1	7030003280	S.RESISTOR	ERJ3GEYJ 470 V (47 Ω)
R2	7030003280	S.RESISTOR	ERJ3GEYJ 470 V (47 Ω)
R3	7030003280	S.RESISTOR	ERJ3GEYJ 470 V (47 Ω)
R4	7030003280	S.RESISTOR	ERJ3GEYJ 470 V (47 Ω)
R5	7410000990	S.ARRAY	EXB-V8V 470JV
R9	7030003680	S.RESISTOR	ERJ3GEYJ 104 V (100 kΩ)
R10	7030003680	S.RESISTOR	ERJ3GEYJ 104 V (100 kΩ)
R11	7030003680	S.RESISTOR	ERJ3GEYJ 104 V (100 kΩ)
R12	7030003680	S.RESISTOR	ERJ3GEYJ 104 V (100 kΩ)
R13	7030003680	S.RESISTOR	ERJ3GEYJ 104 V (100 kΩ)
R14	7030003680	S.RESISTOR	ERJ3GEYJ 104 V (100 kΩ)
R15	7030003680	S.RESISTOR	ERJ3GEYJ 104 V (100 kΩ)
R16	7030003680	S.RESISTOR	ERJ3GEYJ 104 V (100 kΩ)
R17	7030003680	S.RESISTOR	ERJ3GEYJ 104 V (100 kΩ)
R18	7030003680	S.RESISTOR	ERJ3GEYJ 104 V (100 kΩ)
R19	7030003680	S.RESISTOR	ERJ3GEYJ 104 V (100 kΩ)
R20	7030003680	S.RESISTOR	ERJ3GEYJ 104 V (100 kΩ)
R21	7030003680	S.RESISTOR	ERJ3GEYJ 104 V (100 kΩ)
R22	7030003680	S.RESISTOR	ERJ3GEYJ 104 V (100 kΩ)
R23	7030003680	S.RESISTOR	ERJ3GEYJ 104 V (100 kΩ)
R24	7030003680	S.RESISTOR	ERJ3GEYJ 104 V (100 kΩ)
R25	7030003680	S.RESISTOR	ERJ3GEYJ 104 V (100 kΩ)
R26	7030003680	S.RESISTOR	ERJ3GEYJ 104 V (100 kΩ)
R27	7030003680	S.RESISTOR	ERJ3GEYJ 104 V (100 kΩ)
R28	7030003680	S.RESISTOR	ERJ3GEYJ 104 V (100 kΩ)
R29	7030003680	S.RESISTOR	ERJ3GEYJ 104 V (100 kΩ)
R30	7030003680	S.RESISTOR	ERJ3GEYJ 104 V (100 kΩ)
R31	7030003680	S.RESISTOR	ERJ3GEYJ 104 V (100 kΩ)
R32	7030003630	S.RESISTOR	ERJ3GEYJ 393 V (39 kΩ)
R33	7030003630	S.RESISTOR	ERJ3GEYJ 393 V (39 kΩ)
R34	7030003560	S.RESISTOR	ERJ3GEYJ 103 V (10 kΩ)
R35	7030004050	S.RESISTOR	ERJ3GEYJ 1R0 V (1 Ω)
R36	7030004050	S.RESISTOR	ERJ3GEYJ 1R0 V (1 Ω)
R37	7030006600	S.RESISTOR	RR0816P-822-D (8.2 kΩ)
R38	7030006460	S.RESISTOR	RR0816P-152-D (1.5 kΩ)
R39	7030003680	S.RESISTOR	ERJ3GEYJ 104 V (100 kΩ)
R40	7030003680	S.RESISTOR	ERJ3GEYJ 104 V (100 kΩ)
R41	7030003680	S.RESISTOR	ERJ3GEYJ 104 V (100 kΩ)
R42	7030003680	S.RESISTOR	ERJ3GEYJ 104 V (100 kΩ)
R43	7030003360	S.RESISTOR	ERJ3GEYJ 221 V (220 Ω)
R44	7030003360	S.RESISTOR	ERJ3GEYJ 221 V (220 Ω)
R45	7030003360	S.RESISTOR	ERJ3GEYJ 221 V (220 Ω)
R46	7030003360	S.RESISTOR	ERJ3GEYJ 221 V (220 Ω)

[LOGIC UNIT]

REF NO.	ORDER NO.	DESCRIPTION	
R47	7030003360	S.RESISTOR	ERJ3GEYJ 221 V (220 Ω)
R48	7030003360	S.RESISTOR	ERJ3GEYJ 221 V (220 Ω)
R49	7030003360	S.RESISTOR	ERJ3GEYJ 221 V (220 Ω)
R50	7030003360	S.RESISTOR	ERJ3GEYJ 221 V (220 Ω)
R51	7030003360	S.RESISTOR	ERJ3GEYJ 221 V (220 Ω)
R52	7030003360	S.RESISTOR	ERJ3GEYJ 221 V (220 Ω)
R53	7030003360	S.RESISTOR	ERJ3GEYJ 221 V (220 Ω)
R54	7030003360	S.RESISTOR	ERJ3GEYJ 221 V (220 Ω)
R55	7030003360	S.RESISTOR	ERJ3GEYJ 221 V (220 Ω)
R56	7030003590	S.RESISTOR	ERJ3GEYJ 183 V (18 kΩ)
R57	7030003360	S.RESISTOR	ERJ3GEYJ 221 V (220 Ω)
R60	7030003220	S.RESISTOR	ERJ3GEYJ 150 V (15 Ω)
R61	7030003220	S.RESISTOR	ERJ3GEYJ 150 V (15 Ω)
R62	7030003220	S.RESISTOR	ERJ3GEYJ 150 V (15 Ω)
R63	7030003220	S.RESISTOR	ERJ3GEYJ 150 V (15 Ω)
R64	7030003220	S.RESISTOR	ERJ3GEYJ 150 V (15 Ω)
R65	7030003220	S.RESISTOR	ERJ3GEYJ 150 V (15 Ω)
R66	7030003500	S.RESISTOR	ERJ3GEYJ 332 V (3.3 kΩ)
R67	7030003500	S.RESISTOR	ERJ3GEYJ 332 V (3.3 kΩ)
R68	7030003580	S.RESISTOR	ERJ3GEYJ 153 V (15 kΩ)
R69	7030003460	S.RESISTOR	ERJ3GEYJ 152 V (1.5 kΩ)
R70	7030003500	S.RESISTOR	ERJ3GEYJ 332 V (3.3 kΩ)
R71	7030003500	S.RESISTOR	ERJ3GEYJ 332 V (3.3 kΩ)
R72	7030003560	S.RESISTOR	ERJ3GEYJ 103 V (10 kΩ)
R73	7030003520	S.RESISTOR	ERJ3GEYJ 472 V (4.7 kΩ)
R74	7510000900	S.THERMISTOR	NTCCF2012 3SH 223KC-T
R75	7030003740	S.RESISTOR	ERJ3GEYJ 334 V (330 kΩ)
R76	7030003790	S.RESISTOR	ERJ3GEYJ 824 V (820 kΩ)
R77	7030003640	S.RESISTOR	ERJ3GEYJ 473 V (47 kΩ)
R78	7030003840	S.RESISTOR	ERJ3GEYJ 225 V (2.2 MΩ)
R79	7030003810	S.RESISTOR	ERJ3GEYJ 125 V (1.2 MΩ)
R80	7030003650	S.RESISTOR	ERJ3GEYJ 563 V (56 kΩ)
R81	7030003700	S.RESISTOR	ERJ3GEYJ 154 V (150 kΩ)
R82	7030003680	S.RESISTOR	ERJ3GEYJ 104 V (100 kΩ)
R83	7030003400	S.RESISTOR	ERJ3GEYJ 471 V (470 Ω)
R84	7030003640	S.RESISTOR	ERJ3GEYJ 473 V (47 kΩ)
R87	7030003560	S.RESISTOR	ERJ3GEYJ 103 V (10 kΩ)
R88	7030003800	S.RESISTOR	ERJ3GEYJ 105 V (1 MΩ)
R89	7030003640	S.RESISTOR	ERJ3GEYJ 473 V (47 kΩ)
R90	7030003200	S.RESISTOR	ERJ3GEYJ 100 V (10 Ω)
R91	7030003800	S.RESISTOR	ERJ3GEYJ 105 V (1 MΩ)
R92	7030003750	S.RESISTOR	ERJ3GEYJ 394 V (390 kΩ)
R93	7030003800	S.RESISTOR	ERJ3GEYJ 105 V (1 MΩ)
R94	7030003680	S.RESISTOR	ERJ3GEYJ 104 V (100 kΩ)
R95	7030003680	S.RESISTOR	ERJ3GEYJ 104 V (100 kΩ)
R96	7030004120	S.RESISTOR	ERJ3GEYJ 203 V (20 kΩ)
R97	7030003590	S.RESISTOR	ERJ3GEYJ 183 V (18 kΩ)
R98	7030004120	S.RESISTOR	ERJ3GEYJ 203 V (20 kΩ)
R99	7030003560	S.RESISTOR	ERJ3GEYJ 103 V (10 kΩ)
R100	7030003560	S.RESISTOR	ERJ3GEYJ 103 V (10 kΩ)
R101	7030003560	S.RESISTOR	ERJ3GEYJ 103 V (10 kΩ)
R102	7030003440	S.RESISTOR	ERJ3GEYJ 102 V (1 kΩ)
R103	7030003560	S.RESISTOR	ERJ3GEYJ 103 V (10 kΩ)
R104	7030003630	S.RESISTOR	ERJ3GEYJ 393 V (39 kΩ)
R105	7030003640	S.RESISTOR	ERJ3GEYJ 473 V (47 kΩ)
R106	7030003560	S.RESISTOR	ERJ3GEYJ 103 V (10 kΩ)
R107	7030003500	S.RESISTOR	ERJ3GEYJ 332 V (3.3 kΩ)
C1	4030006860	S.CERAMIC	C1608 JB 1H 102K-T-A
C2	4030006860	S.CERAMIC	C1608 JB 1H 102K-T-A
C3	4030006860	S.CERAMIC	C1608 JB 1H 102K-T-A
C4	4030008890	S.CERAMIC	C1608 JB 1C 273K-T-A
C6	4030006860	S.CERAMIC	C1608 JB 1H 102K-T-A
C7	4510006670	S.ELECTROLYTIC	ECEV1CA471P
C8	4030006860	S.CERAMIC	C1608 JB 1H 102K-T-A
C9	4510005370	S.ELECTROLYTIC	ECEV1AA221P
C10	4030011280	S.CERAMIC	C1608 CH 1H 271J-T-A
C11	4030006860	S.CERAMIC	C1608 JB 1H 102K-T-A
C12	4510007120	S.ELECTROLYTIC	ECEV1AA101SP
C13	4030006860	S.CERAMIC	C1608 JB 1H 102K-T-A
C14	4030006860	S.CERAMIC	C1608 JB 1H 102K-T-A
C15	4030006860	S.CERAMIC	C1608 JB 1H 102K-T-A
C16	4030009650	S.CERAMIC	C1608 CH 1H 240J-T-A
C17	4030009650	S.CERAMIC	C1608 CH 1H 240J-T-A
C18	4030007070	S.CERAMIC	C1608 CH 1H 330J-T-A

S.=Surface mount

[LOGIC UNIT]

REF NO.	ORDER NO.	DESCRIPTION	
C19	4030007010	S.CERAMIC	C1608 CH 1H 100D-T-A
C20	4030006860	S.CERAMIC	C1608 JB 1H 102K-T-A
C21	4030006860	S.CERAMIC	C1608 JB 1H 102K-T-A
C22	4030006860	S.CERAMIC	C1608 JB 1H 102K-T-A
C23	4030006860	S.CERAMIC	C1608 JB 1H 102K-T-A
C24	4030006860	S.CERAMIC	C1608 JB 1H 102K-T-A
C25	4030006860	S.CERAMIC	C1608 JB 1H 102K-T-A
C26	4030006860	S.CERAMIC	C1608 JB 1H 102K-T-A
C27	4030006860	S.CERAMIC	C1608 JB 1H 102K-T-A
C28	4030006860	S.CERAMIC	C1608 JB 1H 102K-T-A
C29	4030009990	S.CERAMIC	C1608 CH 1H 200J-T-A
C30	4030006860	S.CERAMIC	C1608 JB 1H 102K-T-A
C31	4550006660	S.TANTALUM	ECST1CC226R
C32	4510005370	S.ELECTROLYTIC	ECEV1AA221P
C33	4030006860	S.CERAMIC	C1608 JB 1H 102K-T-A
C34	4030006860	S.CERAMIC	C1608 JB 1H 102K-T-A
J1	6510019500	S.CONNECTOR	52559-2290
J2	6510021300	S.CONNECTOR	52365-1091
J3	6510021860	CONNECTOR	BH-800.8
DS1	5030001850	LCD	TSD0402-UFFDCW
DS2	5040002310	S.LED	SML-311YTT86
DS3	5040002310	S.LED	SML-311YTT86
DS4	5040002310	S.LED	SML-311YTT86
DS5	5040002310	S.LED	SML-311YTT86
DS6	5040002310	S.LED	SML-311YTT86
DS7	5040002310	S.LED	SML-311YTT86
DS8	5040002310	S.LED	SML-311YTT86
DS9	5040002310	S.LED	SML-311YTT86
DS10	5040002310	S.LED	SML-311YTT86
DS11	5040002310	S.LED	SML-311YTT86
DS12	5040002310	S.LED	SML-311YTT86
DS13	5040002310	S.LED	SML-311YTT86
DS14	5040002310	S.LED	SML-311YTT86
DS15	5040002310	S.LED	SML-311YTT86
DS16	5040002310	S.LED	SML-311YTT86
DS17	5040002310	S.LED	SML-311YTT86
DS18	5040002310	S.LED	SML-311YTT86
DS19	5040002310	S.LED	SML-311YTT86
DS20	5040002310	S.LED	SML-311YTT86
DS21	5040002310	S.LED	SML-311YTT86
DS22	5040002310	S.LED	SML-311YTT86
DS24	5040002310	S.LED	SML-311YTT86
DS25	5040002310	S.LED	SML-311YTT86
DS26	5040002310	S.LED	SML-311YTT86
DS27	5040002310	S.LED	SML-311YTT86
DS28	5040002310	S.LED	SML-311YTT86
DS29	5040002310	S.LED	SML-311YTT86
DS30	5040002310	S.LED	SML-311YTT86
DS31	5040002310	S.LED	SML-311YTT86
DS32	5040002310	S.LED	SML-311YTT86
DS33	5040002310	S.LED	SML-311YTT86
DS34	5040002310	S.LED	SML-311YTT86
DS35	5040002310	S.LED	SML-311YTT86
DS36	5040002310	S.LED	SML-311YTT86
DS37	5040002310	S.LED	SML-311YTT86
DS38	5040002310	S.LED	SML-311YTT86
DS39	5040002310	S.LED	SML-311YTT86
DS40	5040002310	S.LED	SML-311YTT86
DS41	5040002310	S.LED	SML-311YTT86
DS42	5040002310	S.LED	SML-311YTT86
BT1	3020000020	LITHIUM	CR2032
W1	8900006530	CABLE	OPC-618
EP1	0910052953	PCB	B 5475C
EP2	8930052541	LCD CONTACT	SRCN-2349-SP-N-W-1

[MAIN UNIT]

REF NO.	ORDER NO.	DESCRIPTION	
IC1	1110003200	S.IC	TA31136FN (EL)
IC2	1130007610	S.IC	μPD3140GS-E1 (DS8)
IC3	1110003750	S.IC	M5218AFP 600C
IC4	1110003650	S.IC	NJM2211M-TE1
IC5	1170000280	S.IC	TLP121 (GB-TPL)
IC6	1130007420	S.IC	TC7W14FU (TE12L)
IC8	1170000280	S.IC	TLP121 (GB-TPL)
IC9	1110002030	IC	TA7808S
IC10	1180001070	S.IC	TA7805F (TE16L)
Q1	1580000700	S.FET	3SK292 (TE85R)
Q2	1580000490	S.FET	3SK166A-2-T7
Q3	1530002360	S.TRANSISTOR	2SC2714-Y (TE85R)
Q4	1530002850	S.TRANSISTOR	2SC4116-BL (TE85R)
Q5	1560000330	S.FET	2SK210-GR (TE85R)
Q6	1530002600	S.TRANSISTOR	2SC4215-O (TE85R)
Q7	1530002600	S.TRANSISTOR	2SC4215-O (TE85R)
Q8	1530002600	S.TRANSISTOR	2SC4215-O (TE85R)
Q9	1590000660	S.TRANSISTOR	DTC144TU T107
Q11	1530002850	S.TRANSISTOR	2SC4116-BL (TE85R)
Q12	1590000660	S.TRANSISTOR	DTC144TU T107
Q13	1530002850	S.TRANSISTOR	2SC4116-BL (TE85R)
Q14	1590000660	S.TRANSISTOR	DTC144TU T107
Q15	1520000460	S.TRANSISTOR	2SB1132 T100 R
Q16	1590000660	S.TRANSISTOR	DTC144TU T107
Q17	1530002850	S.TRANSISTOR	2SC4116-BL (TE85R)
Q18	1530002850	S.TRANSISTOR	2SC4116-BL (TE85R)
Q19	1530002850	S.TRANSISTOR	2SC4116-BL (TE85R)
Q20	1530002850	S.TRANSISTOR	2SC4116-BL (TE85R)
Q21	1530002850	S.TRANSISTOR	2SC4116-BL (TE85R)
Q22	1530002850	S.TRANSISTOR	2SC4116-BL (TE85R)
D2	1790001330	S.ZENER	MA8036-L (TX)
D4	1790000640	S.VARICAP	MA363B (TX)
D5	1790000640	S.VARICAP	MA363B (TX)
D6	1750000550	S.DIODE	1SS355 TE-17
D8	1750000130	S.DIODE	DA204U T107
D9	1750000550	S.DIODE	1SS355 TE-17
D10	1750000130	S.DIODE	DA204U T107
D11	1750000130	S.DIODE	DA204U T107
D12	1790000950	S.ZENER	MA8056-M (TX)
D13	1790000950	S.ZENER	MA8056-M (TX)
D14	1790000950	S.ZENER	MA8056-M (TX)
FI1	2010002420	MONOLITH	FL-310 (21R15AB)
FI2	2010002420	MONOLITH	FL-310 (21R15AB)
FI3	2020001680	CERAMIC	ALFY450E
X1	6070000210	S.DISCRIMINATOR	CBCA450CX24
X2	6050010800	S.XTAL	CR-659 (21.25 MHz)
L1	6150003820	COIL	LS-440
L2	6150003820	COIL	LS-440
L3	6150003820	COIL	LS-440
L4	6150003820	COIL	LS-440
L5	6200003050	S.COIL	NL 322522T-R82J-3
L6	6200004600	S.COIL	MLF1608D R15K-T
L7	6200002410	S.COIL	NL 252018T-056J
L8	6200003100	S.COIL	NL 322522T-3R9J-3
L9	6130002360	S.COIL	LB-257
L10	6200003090	S.COIL	NL 322522T-2R7J-3
L11	6200004700	S.COIL	MLR1608M R10K-T
L12	6200004700	S.COIL	MLR1608M R10K-T
L13	6200004700	S.COIL	MLR1608M R10K-T
L14	6200004920	S.COIL	MLF1608A 2R2K-T
L15	6200002420	S.COIL	NL 252018T-068J
R1	7030003670	S.RESISTOR	ERJ3GEYJ 823 V (82 kΩ)
R3	7030003620	S.RESISTOR	ERJ3GEYJ 333 V (33 kΩ)
R4	7030003600	S.RESISTOR	ERJ3GEYJ 223 V (22 kΩ)
R5	7030003560	S.RESISTOR	ERJ3GEYJ 103 V (10 kΩ)
R6	7030003640	S.RESISTOR	ERJ3GEYJ 473 V (47 kΩ)
R7	7030003320	S.RESISTOR	ERJ3GEYJ 101 V (100 Ω)
R8	7030003400	S.RESISTOR	ERJ3GEYJ 471 V (470 Ω)
R9	7030003320	S.RESISTOR	ERJ3GEYJ 101 V (100 Ω)
R12	7030003560	S.RESISTOR	ERJ3GEYJ 103 V (10 kΩ)

S.=Surface mount

[MAIN UNIT]

REF NO.	ORDER NO.	DESCRIPTION	
R14	7030003200	S.RESISTOR	ERJ3GEYJ 100 V (10 Ω)
R15	7030003480	S.RESISTOR	ERJ3GEYJ 222 V (2.2 kΩ)
R16	7030003450	S.RESISTOR	ERJ3GEYJ 122 V (1.2 kΩ)
R17	7030003460	S.RESISTOR	ERJ3GEYJ 152 V (1.5 kΩ)
R18	7030003680	S.RESISTOR	ERJ3GEYJ 104 V (100 kΩ)
R20	7030003320	S.RESISTOR	ERJ3GEYJ 101 V (100 Ω)
R21	7030003560	S.RESISTOR	ERJ3GEYJ 103 V (10 kΩ)
R22	7030003400	S.RESISTOR	ERJ3GEYJ 471 V (470 Ω)
R23	7030003450	S.RESISTOR	ERJ3GEYJ 122 V (1.2 kΩ)
R24	7030003460	S.RESISTOR	ERJ3GEYJ 152 V (1.5 kΩ)
R25	7030003390	S.RESISTOR	ERJ3GEYJ 391 V (390 Ω)
R26	7030003740	S.RESISTOR	ERJ3GEYJ 334 V (330 kΩ)
R27	7030003460	S.RESISTOR	ERJ3GEYJ 152 V (1.5 kΩ)
R28	7030003640	S.RESISTOR	ERJ3GEYJ 473 V (47 kΩ)
R29	7310002740	S.TRIMMER	RV-150 (RH03A3A14X0FC) 103
R30	7030003500	S.RESISTOR	ERJ3GEYJ 332 V (3.3 kΩ)
R31	7030003280	S.RESISTOR	ERJ3GEYJ 470 V (47 Ω)
R32	7030003380	S.RESISTOR	ERJ3GEYJ 331 V (330 Ω)
R33	7410000950	S.ARRAY	EXB-V8V 102JV
R34	7030003550	S.RESISTOR	ERJ3GEYJ 822 V (8.2 kΩ)
R36	7030003410	S.RESISTOR	ERJ3GEYJ 561 V (560 Ω)
R37	7030003320	S.RESISTOR	ERJ3GEYJ 101 V (100 Ω)
R38	7030003300	S.RESISTOR	ERJ3GEYJ 680 V (68 Ω)
R39	7030003320	S.RESISTOR	ERJ3GEYJ 101 V (100 Ω)
R40	7030003480	S.RESISTOR	ERJ3GEYJ 222 V (2.2 kΩ)
R41	7030003440	S.RESISTOR	ERJ3GEYJ 102 V (1 kΩ)
R42	7030003440	S.RESISTOR	ERJ3GEYJ 102 V (1 kΩ)
R43	7030003420	S.RESISTOR	ERJ3GEYJ 681 V (680 Ω)
R44	7030003660	S.RESISTOR	ERJ3GEYJ 683 V (68 kΩ)
R45	7030003420	S.RESISTOR	ERJ3GEYJ 681 V (680 Ω)
R46	7030003660	S.RESISTOR	ERJ3GEYJ 683 V (68 kΩ)
R47	7030003320	S.RESISTOR	ERJ3GEYJ 101 V (100 Ω)
R48	7030003500	S.RESISTOR	ERJ3GEYJ 332 V (3.3 kΩ)
R49	7030003480	S.RESISTOR	ERJ3GEYJ 222 V (2.2 kΩ)
R50	7030003320	S.RESISTOR	ERJ3GEYJ 101 V (100 Ω)
R51	7030003360	S.RESISTOR	ERJ3GEYJ 221 V (220 Ω)
R52	7030003550	S.RESISTOR	ERJ3GEYJ 822 V (8.2 kΩ)
R53	7030003460	S.RESISTOR	ERJ3GEYJ 152 V (1.5 kΩ)
R54	7030003760	S.RESISTOR	ERJ3GEYJ 474 V (470 kΩ)
R55	7030003760	S.RESISTOR	ERJ3GEYJ 474 V (470 kΩ)
R56	7030003280	S.RESISTOR	ERJ3GEYJ 470 V (47 Ω)
R57	7030003560	S.RESISTOR	ERJ3GEYJ 103 V (10 kΩ)
R58	7030003560	S.RESISTOR	ERJ3GEYJ 103 V (10 kΩ)
R59	7030003560	S.RESISTOR	ERJ3GEYJ 103 V (10 kΩ)
R60	7030003760	S.RESISTOR	ERJ3GEYJ 474 V (470 kΩ)
R61	7030003640	S.RESISTOR	ERJ3GEYJ 473 V (47 kΩ)
R62	7030003380	S.RESISTOR	ERJ3GEYJ 331 V (330 Ω)
R63	7030003680	S.RESISTOR	ERJ3GEYJ 104 V (100 kΩ)
R64	7030003630	S.RESISTOR	ERJ3GEYJ 393 V (39 kΩ)
R65	7030003580	S.RESISTOR	ERJ3GEYJ 153 V (15 kΩ)
R66	7310002720	S.TRIMMER	RV-148 (RH03A3AS3X0DA) 472
R67	7030003580	S.RESISTOR	ERJ3GEYJ 153 V (15 kΩ)
R68	7030003440	S.RESISTOR	ERJ3GEYJ 102 V (1 kΩ)
R69	7030003440	S.RESISTOR	ERJ3GEYJ 102 V (1 kΩ)
R70	7030003280	S.RESISTOR	ERJ3GEYJ 470 V (47 Ω)
R72	7030003540	S.RESISTOR	ERJ3GEYJ 682 V (6.8 kΩ)
R73	7030003400	S.RESISTOR	ERJ3GEYJ 471 V (470 Ω)
R74	7030003400	S.RESISTOR	ERJ3GEYJ 471 V (470 Ω)
R75	7030003540	S.RESISTOR	ERJ3GEYJ 682 V (6.8 kΩ)
R76	7030003680	S.RESISTOR	ERJ3GEYJ 104 V (100 kΩ)
R77	7030003210	S.RESISTOR	ERJ3GEYJ 120 V (12 Ω)
R78	7030003520	S.RESISTOR	ERJ3GEYJ 472 V (4.7 kΩ)
R79	7030003610	S.RESISTOR	ERJ3GEYJ 273 V (27 kΩ)
R80	7030003680	S.RESISTOR	ERJ3GEYJ 104 V (100 kΩ)
R81	7030003610	S.RESISTOR	ERJ3GEYJ 273 V (27 kΩ)
R82	7030003520	S.RESISTOR	ERJ3GEYJ 472 V (4.7 kΩ)
R83	7030003210	S.RESISTOR	ERJ3GEYJ 120 V (12 Ω)
R84	7030003560	S.RESISTOR	ERJ3GEYJ 103 V (10 kΩ)
R85	7030003480	S.RESISTOR	ERJ3GEYJ 222 V (2.2 kΩ)
R86	7030003280	S.RESISTOR	ERJ3GEYJ 470 V (47 Ω)
R87	7030003280	S.RESISTOR	ERJ3GEYJ 470 V (47 Ω)
R88	7030003280	S.RESISTOR	ERJ3GEYJ 470 V (47 Ω)
R89	7410000990	S.ARRAY	EXB-V8V 470JV
R90	7030003620	S.RESISTOR	ERJ3GEYJ 333 V (33 kΩ)
R91	7030003320	S.RESISTOR	ERJ3GEYJ 101 V (100 Ω)
R94	7030003410	S.RESISTOR	ERJ3GEYJ 561 V (560 Ω)
R95	7030003320	S.RESISTOR	ERJ3GEYJ 101 V (100 Ω)
R96	7030003320	S.RESISTOR	ERJ3GEYJ 101 V (100 Ω)
R97	7030003550	S.RESISTOR	ERJ3GEYJ 822 V (8.2 kΩ)
R98	7030003550	S.RESISTOR	ERJ3GEYJ 822 V (8.2 kΩ)
R99	7030003770	S.RESISTOR	ERJ3GEYJ 564 V (560 kΩ)
R100	7030003710	S.RESISTOR	ERJ3GEYJ 184 V (180 kΩ)

[MAIN UNIT]

REF NO.	ORDER NO.	DESCRIPTION	
R101	7030003490	S.RESISTOR	ERJ3GEYJ 272 V (2.7 kΩ)
R102	7030003380	S.RESISTOR	ERJ3GEYJ 331 V (330 Ω)
R103	7030003620	S.RESISTOR	ERJ3GEYJ 333 V (33 kΩ)
R104	7030003620	S.RESISTOR	ERJ3GEYJ 333 V (33 kΩ)
R105	7030003480	S.RESISTOR	ERJ3GEYJ 222 V (2.2 kΩ)
R106	7030003680	S.RESISTOR	ERJ3GEYJ 104 V (100 kΩ)
R107	7030003290	S.RESISTOR	ERJ3GEYJ 560 V (56 Ω)
R108	7030003520	S.RESISTOR	ERJ3GEYJ 472 V (4.7 kΩ)
R109	7030003520	S.RESISTOR	ERJ3GEYJ 472 V (4.7 kΩ)
R111	7030003560	S.RESISTOR	ERJ3GEYJ 103 V (10 kΩ)
R112	7030003560	S.RESISTOR	ERJ3GEYJ 103 V (10 kΩ)
R113	7030003560	S.RESISTOR	ERJ3GEYJ 103 V (10 kΩ)
R114	7030003440	S.RESISTOR	ERJ3GEYJ 102 V (1 kΩ)
R115	7030003670	S.RESISTOR	ERJ3GEYJ 823 V (82 kΩ)
R116	7030003580	S.RESISTOR	ERJ3GEYJ 153 V (15 kΩ)
R117	7030003440	S.RESISTOR	ERJ3GEYJ 102 V (1 kΩ)
R118	7030003330	S.RESISTOR	ERJ3GEYJ 121 V (120 Ω)
R119	7030003680	S.RESISTOR	ERJ3GEYJ 104 V (100 kΩ)
R120	7030003520	S.RESISTOR	ERJ3GEYJ 472 V (4.7 kΩ)
R121	7030003200	S.RESISTOR	ERJ3GEYJ 100 V (10 Ω)
R123	7030003620	S.RESISTOR	ERJ3GEYJ 333 V (33 kΩ)
C1	4030006990	S.CERAMIC	C1608 CH 1H 080D-T-A
C2	4030006990	S.CERAMIC	C1608 CH 1H 080D-T-A
C3	4030006980	S.CERAMIC	C1608 CH 1H 070D-T-A
C4	4030009510	S.CERAMIC	C1608 CH 1H 010B-T-A
C5	4030006860	S.CERAMIC	C1608 JB 1H 102K-T-A
C6	4030007170	S.CERAMIC	C1608 CH 1H 221J-T-A
C7	4030006860	S.CERAMIC	C1608 JB 1H 102K-T-A
C8	4030006850	S.CERAMIC	C1608 JB 1H 471K-T-A
C9	4030006860	S.CERAMIC	C1608 JB 1H 102K-T-A
C10	4030006850	S.CERAMIC	C1608 JB 1H 471K-T-A
C11	4030006990	S.CERAMIC	C1608 CH 1H 080D-T-A
C12	4030006970	S.CERAMIC	C1608 CH 1H 060D-T-A
C13	4030006970	S.CERAMIC	C1608 CH 1H 060D-T-A
C14	4030006980	S.CERAMIC	C1608 CH 1H 070D-T-A
C15	4030009500	S.CERAMIC	C1608 CH 1H 0R5B-T-A
C16	4030009500	S.CERAMIC	C1608 CH 1H 0R5B-T-A
C17	4030006990	S.CERAMIC	C1608 CH 1H 080D-T-A
C18	4030006900	S.CERAMIC	C1608 JB 1E 103K-T-A
C19	4030006860	S.CERAMIC	C1608 JB 1H 102K-T-A
C20	4030009920	S.CERAMIC	C1608 CH 1H 050B-T-A
C21	4030006860	S.CERAMIC	C1608 JB 1H 102K-T-A
C22	4030007110	S.CERAMIC	C1608 CH 1H 680J-T-A
C23	4030006860	S.CERAMIC	C1608 JB 1H 102K-T-A
C25	4030011770	S.CERAMIC	C1608 CH 1H 060B-T-A
C27	4030006860	S.CERAMIC	C1608 JB 1H 102K-T-A
C28	4030006900	S.CERAMIC	C1608 JB 1E 103K-T-A
C29	4030008880	S.CERAMIC	C1608 JB 1C 223K-T-A
C30	4030006860	S.CERAMIC	C1608 JB 1H 102K-T-A
C31	4030006900	S.CERAMIC	C1608 JB 1E 103K-T-A
C32	4030008880	S.CERAMIC	C1608 JB 1C 223K-T-A
C33	4030006860	S.CERAMIC	C1608 JB 1H 102K-T-A
C34	4030006860	S.CERAMIC	C1608 JB 1H 102K-T-A
C36	4030006860	S.CERAMIC	C1608 JB 1H 102K-T-A
C37	4030007080	S.CERAMIC	C1608 CH 1H 390J-T-A
C38	4030007080	S.CERAMIC	C1608 CH 1H 390J-T-A
C39	4030006860	S.CERAMIC	C1608 JB 1H 102K-T-A
C40	4030011600	S.CERAMIC	C1608 JB 1C 104KT-N
C41	4030007130	S.CERAMIC	C1608 CH 1H 101J-T-A
C42	4030006860	S.CERAMIC	C1608 JB 1H 102K-T-A
C43	4030006860	S.CERAMIC	C1608 JB 1H 102K-T-A
C44	4030011600	S.CERAMIC	C1608 JB 1C 104KT-N
C45	4030007090	S.CERAMIC	C1608 CH 1H 470J-T-A
C46	4030011600	S.CERAMIC	C1608 JB 1C 104KT-N
C47	4510004630	S.ELECTROLYTIC	ECEV1CA100SR
C48	4030006900	S.CERAMIC	C1608 JB 1E 103K-T-A
C49	4030006860	S.CERAMIC	C1608 JB 1H 102K-T-A
C50	4030011600	S.CERAMIC	C1608 JB 1C 104KT-N
C51	4030006860	S.CERAMIC	C1608 JB 1H 102K-T-A
C52	4030006900	S.CERAMIC	C1608 JB 1E 103K-T-A
C53	4030012600	S.CERAMIC	C2012 JB 1A 105M-T-A
C54	4030007160	S.CERAMIC	C1608 CH 1H 181J-T-A
C55	4030007160	S.CERAMIC	C1608 CH 1H 181J-T-A
C56	4030007040	S.CERAMIC	C1608 CH 1H 180J-T-A
C57	4610002150	S.TRIMMER	CTZ3S-10A-W1-AF
C58	4030007020	S.CERAMIC	C1608 CH 1H 102K-T-A
C59	4030011600	S.CERAMIC	C1608 JB 1C 104KT-N
C60	4030006900	S.CERAMIC	C1608 JB 1E 103K-T-A
C61	4030006860	S.CERAMIC	C1608 JB 1H 102K-T-A
C62	4030008880	S.CERAMIC	C1608 JB 1C 223K-T-A

S.=Surface mount

[MAIN UNIT]

REF NO.	ORDER NO.	DESCRIPTION	
C63	4030006900	S.CERAMIC	C1608 JB 1E 103K-T-A
C64	4550006170	S.TANTALUM	ECST1AY225R
C66	4030006860	S.CERAMIC	C1608 JB 1H 102K-T-A
C67	4030011600	S.CERAMIC	C1608 JB 1C 104KT-N
C68	4030012600	S.CERAMIC	C2012 JB 1A 105M-T-A
C69	4030006850	S.CERAMIC	C1608 JB 1H 471K-T-A
C70	4550000530	S.TANTALUM	TESVA 1V 104M1-8L
C72	4030009520	S.CERAMIC	C1608 CH 1H 020B-T-A
C73	4030009520	S.CERAMIC	C1608 CH 1H 020B-T-A
C74	4030009910	S.CERAMIC	C1608 CH 1H 040B-T-A
C75	4030009560	S.CERAMIC	C1608 CH 1H R75B-T-A
C76	4030006860	S.CERAMIC	C1608 JB 1H 102K-T-A
C77	4030006900	S.CERAMIC	C1608 JB 1E 103K-T-A
C78	4030009990	S.CERAMIC	C1608 CH 1H 200J-T-A
C79	4030006860	S.CERAMIC	C1608 JB 1H 102K-T-A
C80	4030009920	S.CERAMIC	C1608 CH 1H 050B-T-A
C81	4030007020	S.CERAMIC	C1608 CH 1H 120J-T-A
C82	4030006860	S.CERAMIC	C1608 JB 1H 102K-T-A
C83	4030007020	S.CERAMIC	C1608 CH 1H 120J-T-A
C84	4030006860	S.CERAMIC	C1608 JB 1H 102K-T-A
C85	4030006900	S.CERAMIC	C1608 JB 1E 103K-T-A
C86	4030006900	S.CERAMIC	C1608 JB 1E 103K-T-A
C87	4030008850	S.CERAMIC	C1608 JB 1C 123K-T-A
C88	4030008900	S.CERAMIC	C1608 JB 1C 333K-T-A
C89	4030008900	S.CERAMIC	C1608 JB 1C 333K-T-A
C90	4030006850	S.CERAMIC	C1608 JB 1H 471K-T-A
C91	4030008920	S.CERAMIC	C1608 JB 1C 473K-T-A
C92	4030011810	S.CERAMIC	C1608 JB 1A 224K-T-N
C93	4030011600	S.CERAMIC	C1608 JB 1C 104KT-N
C94	4030011600	S.CERAMIC	C1608 JB 1C 104KT-N
C95	4510004630	S.ELECTROLYTIC	ECEV1CA100SR
C96	4030011600	S.CERAMIC	C1608 JB 1C 104KT-N
C97	4340000020	S.MYLAR	ECWU 1C 333JB5
C98	4030011600	S.CERAMIC	C1608 JB 1C 104KT-N
C99	4030006870	S.CERAMIC	C1608 JB 1H 222K-T-A
C100	4030006900	S.CERAMIC	C1608 JB 1E 103K-T-A
C101	4030006880	S.CERAMIC	C1608 JB 1H 472K-T-A
C102	4030011600	S.CERAMIC	C1608 JB 1C 104KT-N
C103	4030011600	S.CERAMIC	C1608 JB 1C 104KT-N
C104	4030006850	S.CERAMIC	C1608 JB 1H 471K-T-A
C106	4030006880	S.CERAMIC	C1608 JB 1H 472K-T-A
C107	4030011600	S.CERAMIC	C1608 JB 1C 104KT-N
C108	4030007090	S.CERAMIC	C1608 CH 1H 470J-T-A
C109	4030006860	S.CERAMIC	C1608 JB 1H 102K-T-A
C110	4030006900	S.CERAMIC	C1608 JB 1E 103K-T-A
C111	4510004590	ELECTROLYTIC	16 MV 470 HC
C112	4030006900	S.CERAMIC	C1608 JB 1E 103K-T-A
C113	4030011600	S.CERAMIC	C1608 JB 1C 104KT-N
C114	4030011600	S.CERAMIC	C1608 JB 1C 104KT-N
C115	4510004630	S.ELECTROLYTIC	ECEV1CA100SR
C116	4030006900	S.CERAMIC	C1608 JB 1E 103K-T-A
C117	4030011600	S.CERAMIC	C1608 JB 1C 104KT-N
C118	4030011600	S.CERAMIC	C1608 JB 1C 104KT-N
C119	4510004630	S.ELECTROLYTIC	ECEV1CA100SR
C120	4030006860	S.CERAMIC	C1608 JB 1H 102K-T-A
C121	4030007090	S.CERAMIC	C1608 CH 1H 470J-T-A
C123	4030011600	S.CERAMIC	C1608 JB 1C 104KT-N
C124	4550006150	S.TANTALUM	ECST1CY105R
C126	4030011600	S.CERAMIC	C1608 JB 1C 104KT-N
C127	4030011600	S.CERAMIC	C1608 JB 1C 104KT-N
C130	4030012600	S.CERAMIC	C2012 JB 1A 105M-T-A
C131	4550006130	S.TANTALUM	ECST1VY224R
C132	4030008890	S.CERAMIC	C1608 JB 1C 273K-T-A
C133	4030008890	S.CERAMIC	C1608 JB 1C 273K-T-A
C134	4030006870	S.CERAMIC	C1608 JB 1H 222K-T-A
C135	4030009490	S.CERAMIC	C1608 JB 1H 821K-T-A
C136	4510004630	S.ELECTROLYTIC	ECEV1CA100SR
C137	4030011600	S.CERAMIC	C1608 JB 1C 104KT-N
C138	4030006860	S.CERAMIC	C1608 JB 1H 102K-T-A
C139	4030006860	S.CERAMIC	C1608 JB 1H 102K-T-A
C140	4510004630	S.ELECTROLYTIC	ECEV1CA100SR
C141	4030006860	S.CERAMIC	C1608 JB 1H 102K-T-A
C142	4030006900	S.CERAMIC	C1608 JB 1E 103K-T-A
C143	4030006900	S.CERAMIC	C1608 JB 1E 103K-T-A
C144	4030006860	S.CERAMIC	C1608 JB 1H 102K-T-A
C145	4030007030	S.CERAMIC	C1608 CH 1H 150J-T-A
C146	4030007030	S.CERAMIC	C1608 CH 1H 150J-T-A
C147	4030006860	S.CERAMIC	C1608 JB 1H 102K-T-A
C148	4030006860	S.CERAMIC	C1608 JB 1H 102K-T-A
C149	4030011600	S.CERAMIC	C1608 JB 1C 104KT-N
C150	4030006860	S.CERAMIC	C1608 JB 1H 102K-T-A
C151	4030006900	S.CERAMIC	C1608 JB 1E 103K-T-A

[MAIN UNIT]

REF NO.	ORDER NO.	DESCRIPTION	
C152	4030006860	S.CERAMIC	C1608 JB 1H 102K-T-A
C153	4030006860	S.CERAMIC	C1608 JB 1H 102K-T-A
C154	4550006830	S.TANTALUM	ECST1DY475R
C155	4030009490	S.CERAMIC	C1608 JB 1H 821K-T-A
C156	4030006870	S.CERAMIC	C1608 JB 1H 222K-T-A
C157	4510004630	S.ELECTROLYTIC	ECEV1CA100SR
J1	6510022310	S.CONNECTOR	B5B-PH-SM3-TB
J2	6510022030	S.CONNECTOR	B10B-ZR-SM3-TF
J3	6510019500	S.CONNECTOR	52559-2290
J4	6510003380	S.CONNECTOR	B02B-EH-S
DS1	5040002310	S.LED	SML-311YTT86
T1	5920000570	TRANSFORMER	12T01
SP1	2520000110	PIEZO BUZZER	PS1740P02
EP1	0910052942	PCB	B 5473B

S.=Surface mount

SECTION 6 MECHANICAL PARTS

[CHASSIS PARTS]

REF. NO.	ORDER NO.	DESCRIPTION	QTY.
J1	6510004880	Connector MR-DS-E 01	1
W1	8900009740	Cable OPC-945	1
W2	8900009690	Cable OPC-951	1
EP1	6910011940	Bead ZCAT2436-1330A-M	1
MP3	8410002340	2349 heatsink	1
MP4	8210017200	2349 front panel assembly	1
MP5	8210017150	2345 rear panel assembly	1
MP6	8930052060	2345 F-packing	1
MP7	8930052050	2345 R-packing	1
MP16	8930052430	2345 A-IC crip	1
MP18	8810008660	Screw PH BT M3 × 8 NI-ZU	5
MP19	8810008660	Screw PH BT M3 × 8 NI-ZU	7
MP20	8810004540	Screw M3 × 8 SUS	6
MP21	8810006050	Icom screw E7	6
MP22	8930052290	O ring (AD)	6
MP23	8850000690	Flat washer M3 (3×7×0.5) SUS	6
MP25	8810004540	Screw M3 × 8 SUS	2
MP26	8930034300	1542 ANT seal	1
MP27	8930049320	2288 VENT. sheet	1

[MAIN UNIT]

REF. NO.	ORDER NO.	DESCRIPTION	QTY.
SP1	2520000110	Piezo buzzer PS1740P02	1
MP1	8510012590	2289 VCO case	1

[LOGIC UNIT]

REF. NO.	ORDER NO.	DESCRIPTION	QTY.
J3	6510021860	Connector BH-800.8	1
BT1	3020000110	Lithium CR2032	1
DS1	5030001850	LCD TSD0402-UFFDCW	1
EP2	8930052541	LCD contact SRCN-2349-SP-N-W-1	2
MP1	8210016790	2349 reflector	1
MP2	8930051950	2349 LCD holder	1
MP3	8930052530	2349 LCD filter	1

[UNPACKING]

REF. NO.	ORDER NO.	DESCRIPTION	QTY.
MP1	8610010560	2040 knob bolt (black)	2
MP2	8010018151	2345 mobile bracket-1	1
MP3	8850000500	Spring washer M5 SUS	2
MP4	8810001490	Screw PH A M5 × 20 SUS	2
MP5	8850000180	Flat washer M5 SUS	2

Screw abbreviations PH: Pan head BT: Self-Tapping
 SUS: Stainless NI-ZU: Nickel-zinc

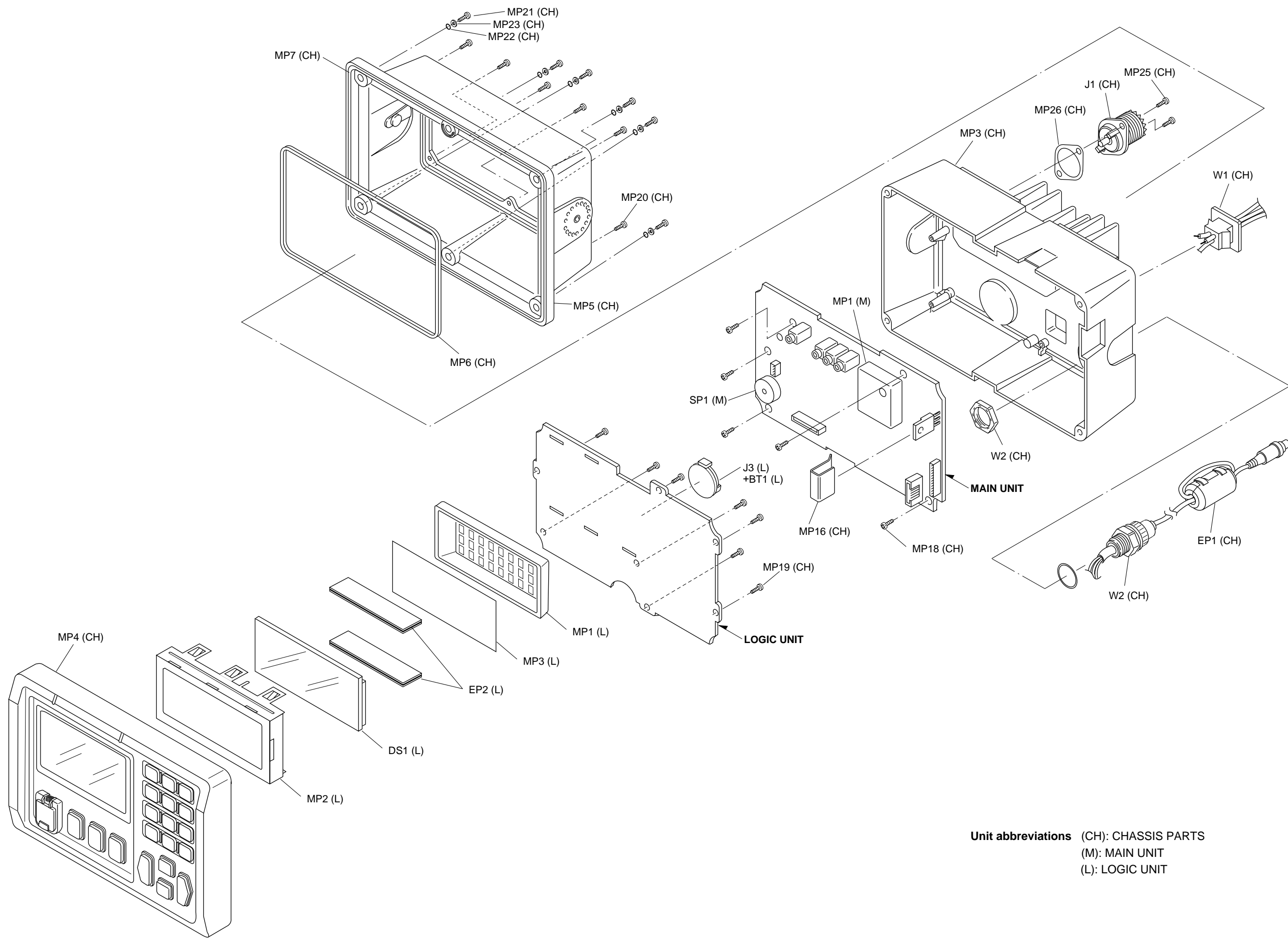

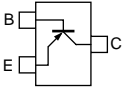
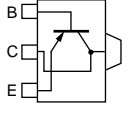
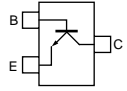
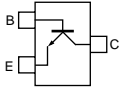
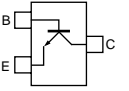
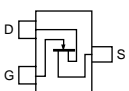
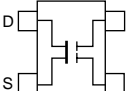
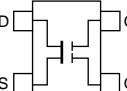
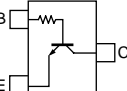
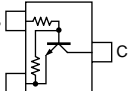

SECTION 7 SEMI-CONDUCTOR INFORMATION

• TRANSISTORS AND FET'S

2SA1362 GR (Symbol: AEG) 	2SB1132 T100 R (Symbol: BAR) 	2SC2714 Y (Symbol: QY) 	2SC4116 BL (Symbol: LL) 	2SC4215 O (Symbol: QO) 
2SK210 GR (Symbol: YG) 	3SK166A-2-T7 (Symbol: K) 	3SK292 (Symbol: UK) 	DTC144 TU T107 (Symbol: 06) 	RN1404 (Symbol: XD) 

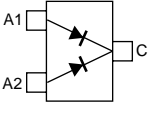
• DIODES

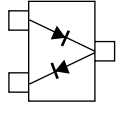
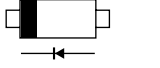
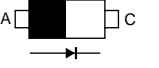
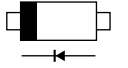
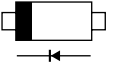
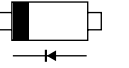
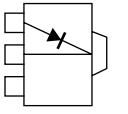
1SS184 (Symbol: B3) 	1SS355 (Symbol: A) 	DA204 U T107 (Symbol: K) 	HSU88TRF (Symbol: 9) 	MA363 B (Symbol: 6D) 
MA8036 L (Symbol: 3_6) 	MA8043 L (Symbol: 4_3) 	MA8056 M (Symbol: 5-6) 	SB10 05PCP TD (Symbol: SA) 	

SECTION 8 BOARD LAYOUTS

8-1 LOGIC UNIT

• TOP VIEW

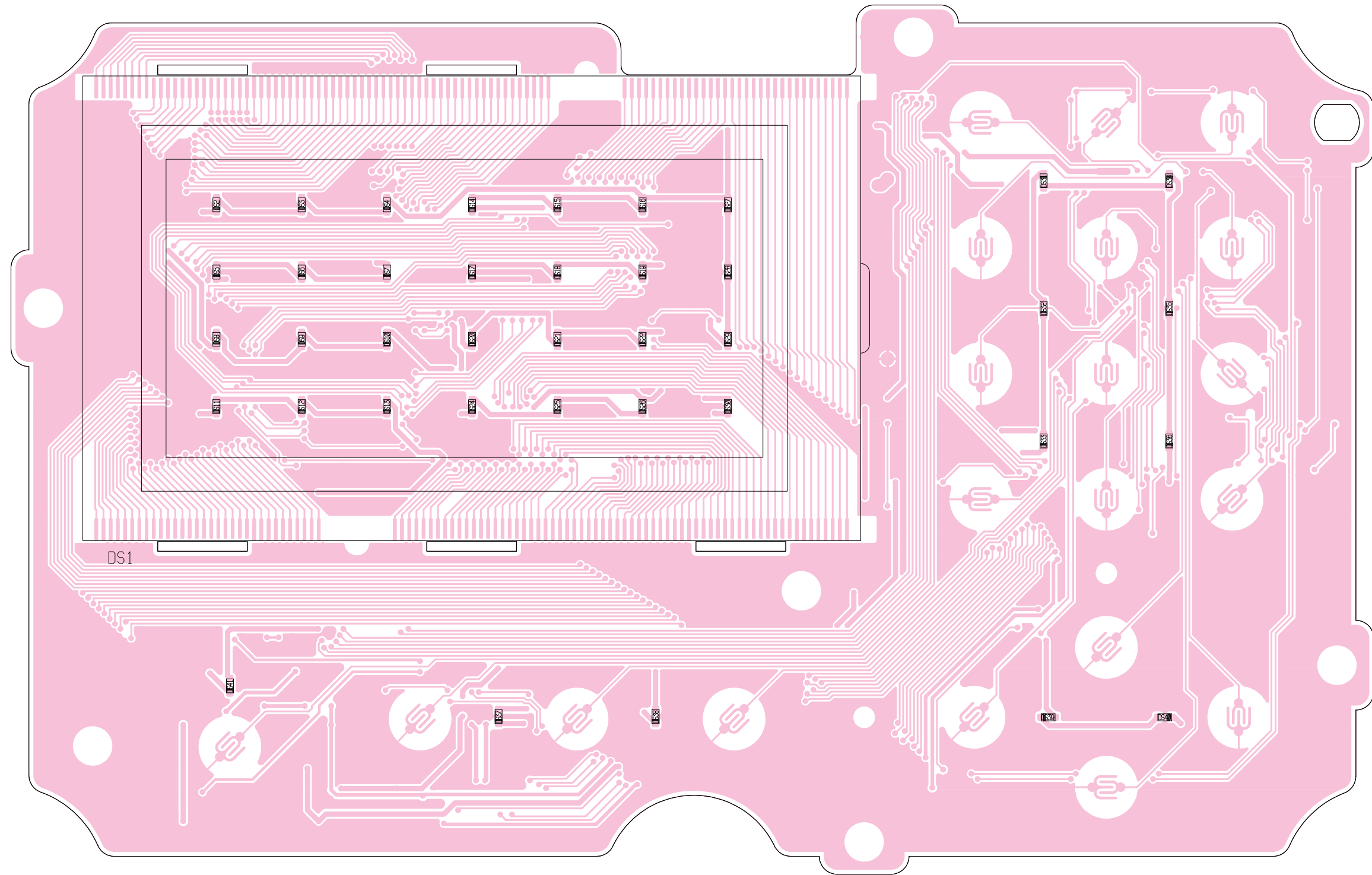

• BOTTOM VIEW

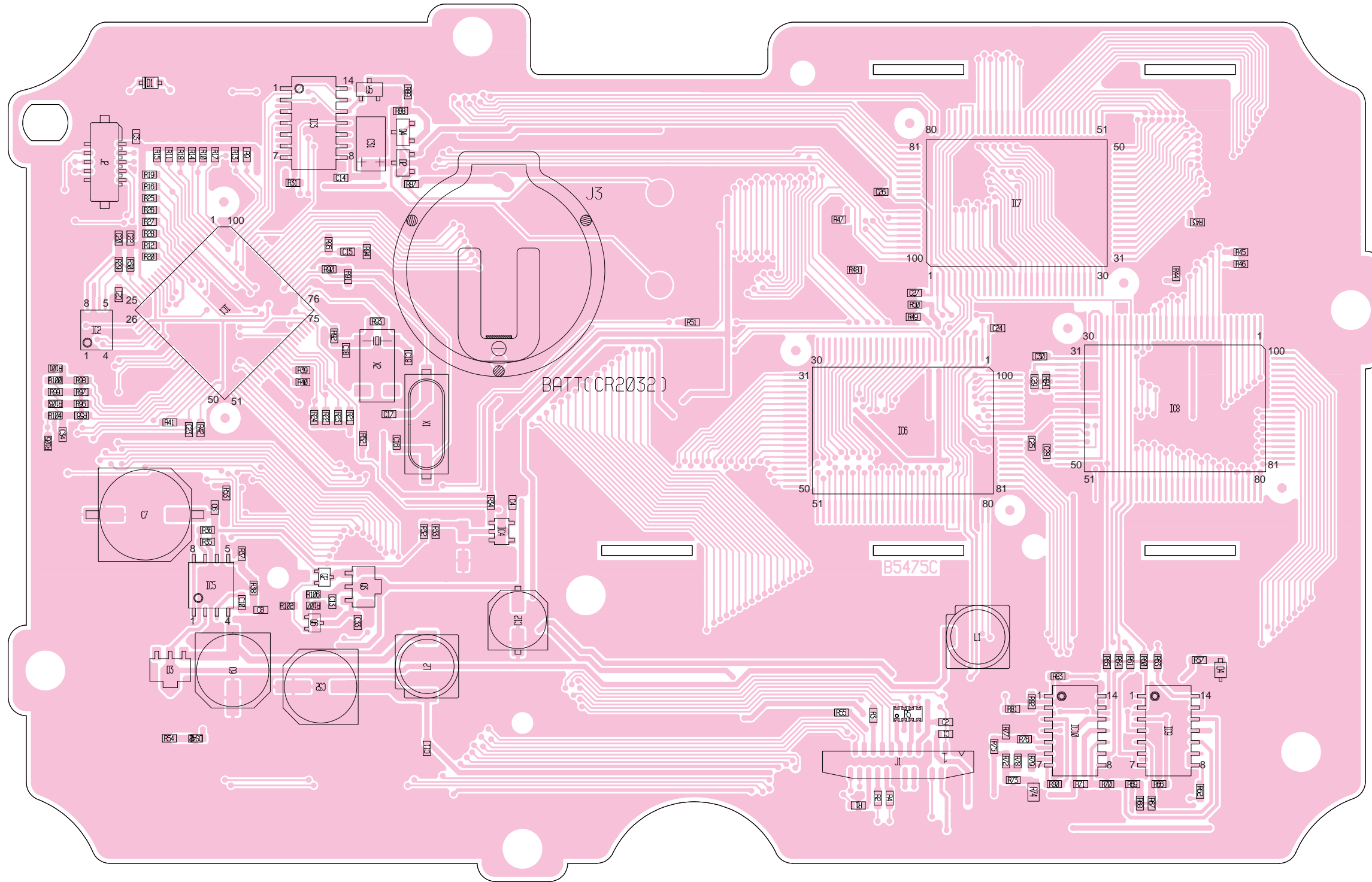

21	PCK	1
20	UNLK	
19	CLTX	
18	RCEV	
17	DDEC	
16	GND	
15	NMEA0	
14	DATAS	
13	GND	
12	BUSY	
11	Vcc	
10	8V	
9	GND	
8	BEEP	
7		
6		
5		
4		
3		
2		
1		

to MAIN unit J3

8-2 MAIN UNIT

• TOP VIEW

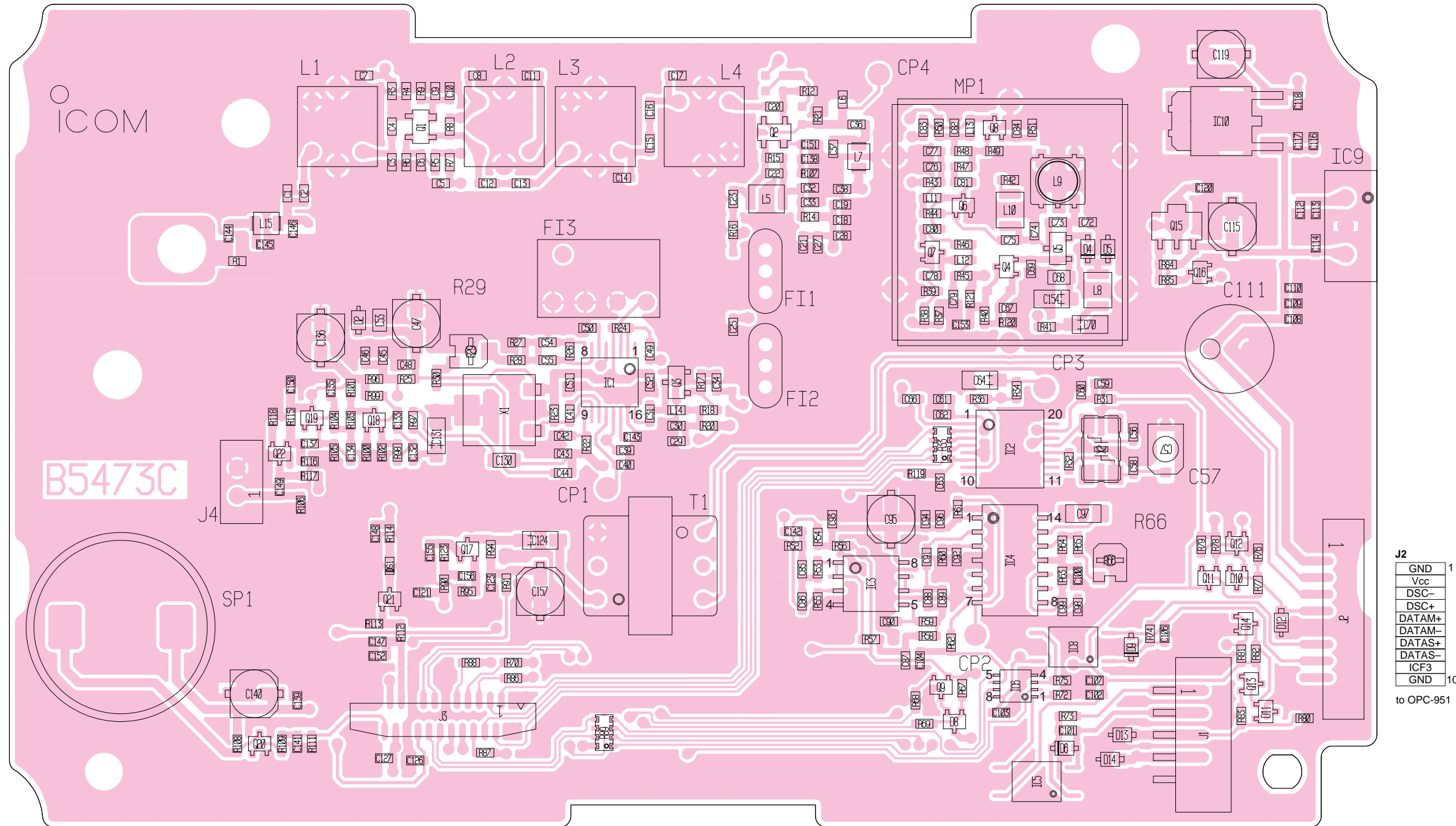

21	Vcc	1
20	BUSY	
19	GND	
18	5V	
17	DATAM	
16	NMEA1	
15	DSMOD	
14	SQL	
13	CLR X	
12	UNLK	
11	PCK	
10		
9		
8		
7		
6		
5		
4		
3		
2		
1		

to LOGIC unit J1

1	NMEA1+	
2	NMEA1-	
3	NMEA0+	to OPC-945
4	ICF3	
5	GND	

1	GND
2	Vcc
3	DSC-
4	DSC+
5	DATAM+
6	DATAM-
7	DATAS+
8	DATAS-
9	ICF3
10	GND

to OPC-951

SECTION 9 BLOCK DIAGRAM

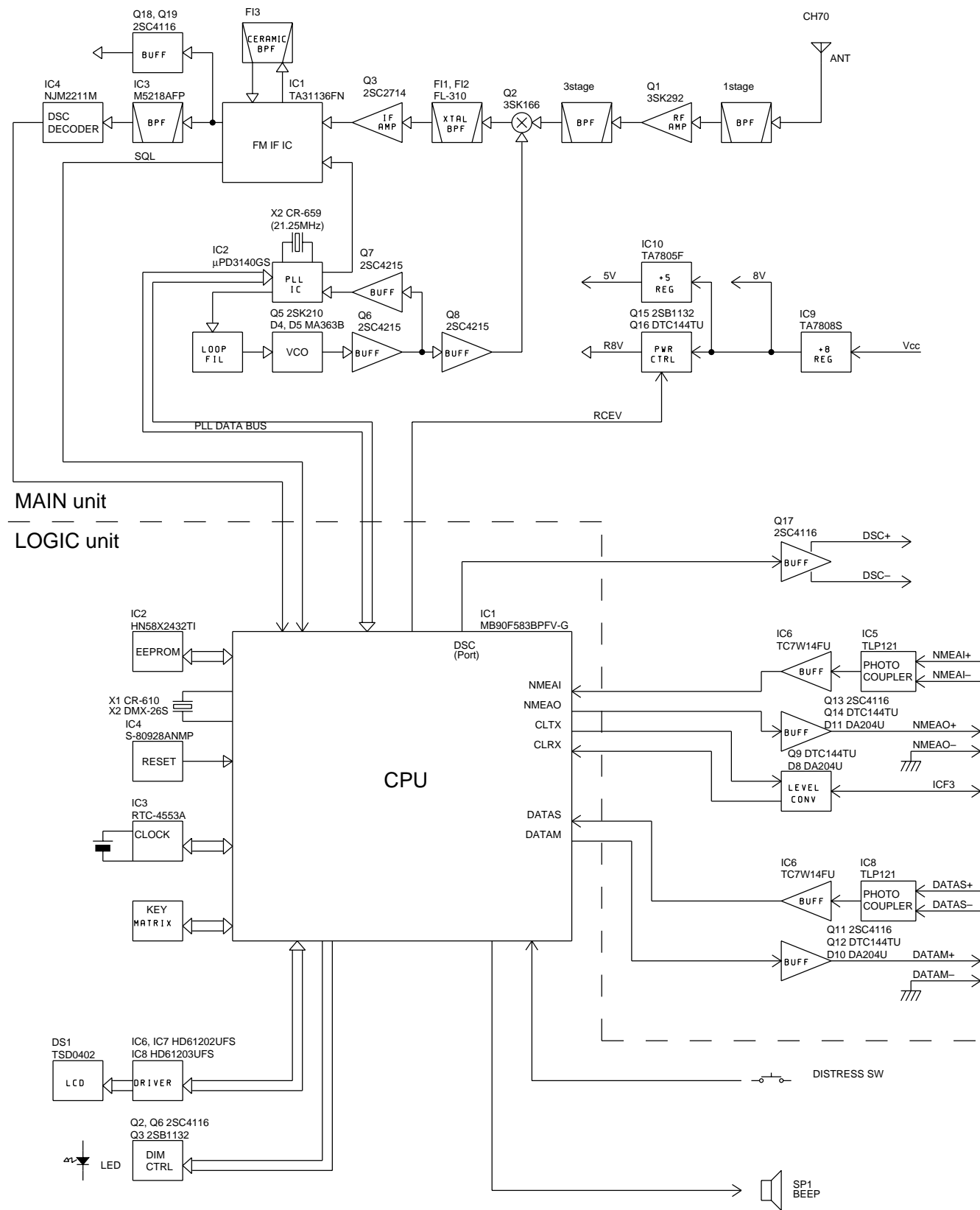

SECTION 10 VOLTAGE DIAGRAM

10-1 LOGIC UNIT

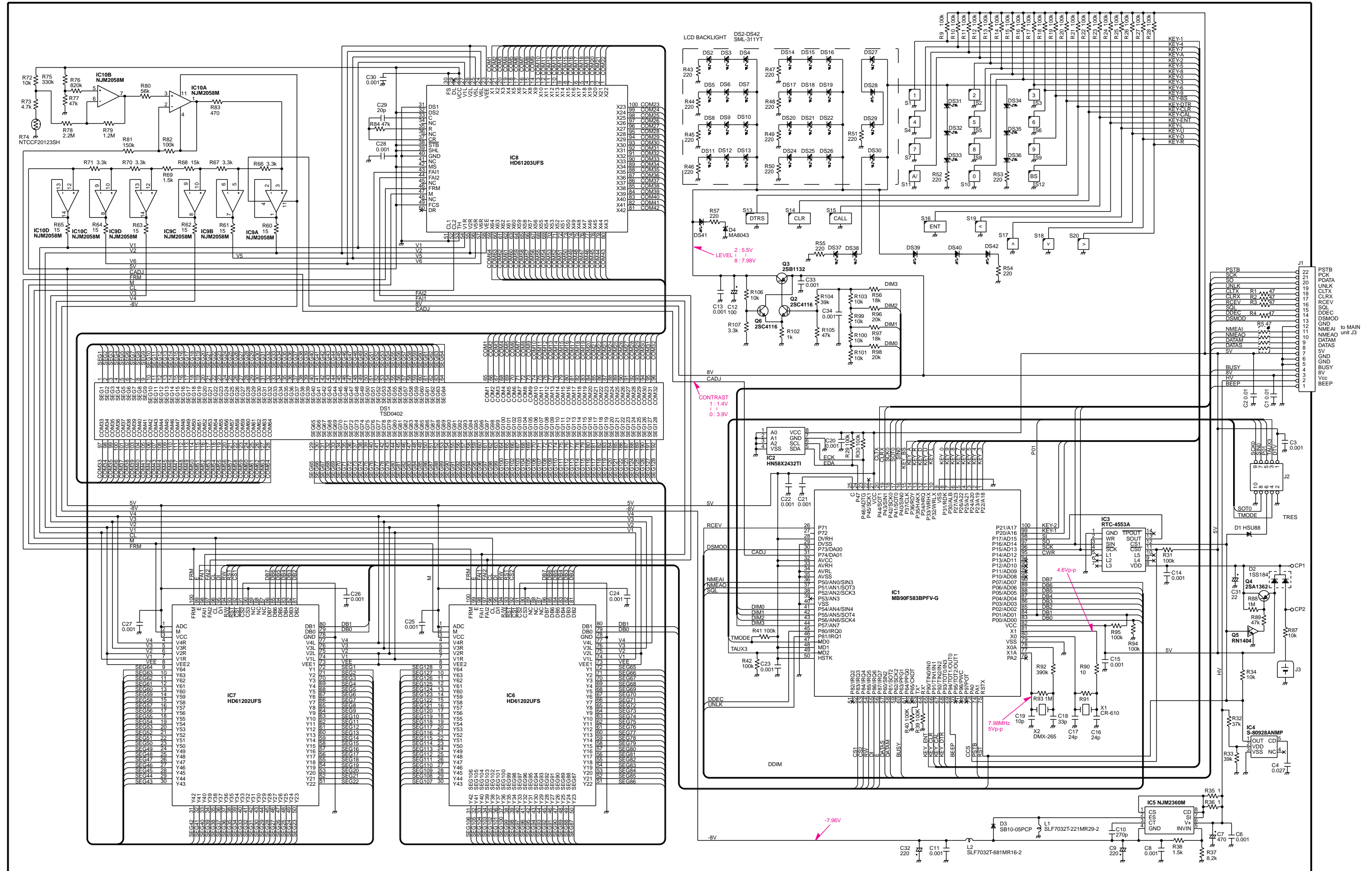

10-2 MAIN UNIT

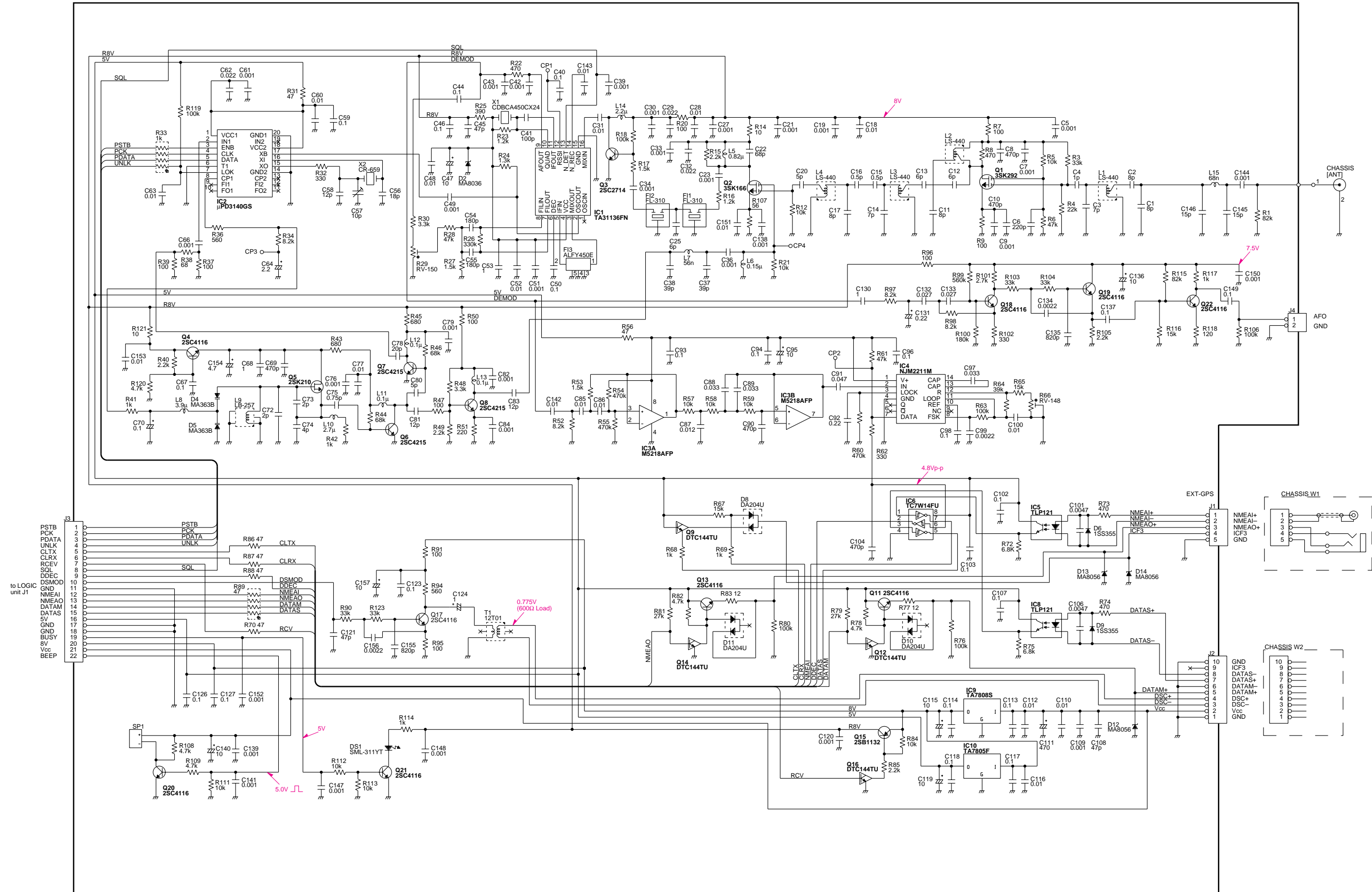

Icom Inc.

1-1-32, Kamiminami, Hirano-ku, Osaka 547-0003, Japan
Phone : 06 6793 5302
Fax : 06 6793 0013
URL : <http://www.icom.co.jp/world/index.html>

Icom America Inc.

<Corporate Headquarters>
2380 116th Avenue N.E., Bellevue, WA 98004, U.S.A.
Phone : (425) 454-8155 Fax : (425) 454-1509
URL : <http://www.icomamerica.com>
<Customer Service>
Phone : (425) 454-7619

Icom Canada

Glenwood Centre #150-6165
Highway 17 Delta, B.C., V4K 5B8, Canada
Phone : (604) 952-4266 Fax : (604) 952-0090
URL : <http://www.icomcanada.com>

Icom (Australia) Pty. Ltd.

A.B.N. 88 006 092 575
290-294 Albert Street, Brunswick, Victoria, 3056, Australia
Phone : 03 9387 0666 Fax : 03 9387 0022
URL : <http://www.icom.net.au>

Icom New Zealand

146A Harris Road, East Tamaki,
Auckland, New Zealand
Phone : 09 274 4062 Fax : 09 274 4708

Asia Icom Inc.

6F No. 68, Sec. 1 Cheng-Teh Road, Taipei, Taiwan, R.O.C.
Phone : (02) 2559 1899 Fax : (02) 2559 1874

Icom (Europe) GmbH

Communication Equipment
Himmelgeister Str. 100, D-40225 Düsseldorf, Germany
Phone : 0211 346047 Fax : 0211 333639
URL : <http://www.icomeurope.com>

Icom Spain S.L

Crta. de Gracia a Manresa Km. 14,750
08190 Sant Cugat del Valles Barcelona, SPAIN
Phone : (93) 590 26 70 Fax : (93) 589 04 46
URL : <http://www.icomspain.com>

Icom (UK) Ltd.

Unit 9, Sea St., Herne Bay, Kent, CT6 8LD, U.K.
Phone : 01227 741741 Fax : 01227 741742
URL : <http://www.icomuk.co.uk>

Icom France S.a

Zac de la Plaine, Rue Brindejonc des Moulinais
BP 5804, 31505 Toulouse Cedex, France
Phone : 561 36 03 03 Fax : 561 36 03 00
URL : <http://www.icom-france.com>

Count on us!

Icom Inc.

1-1-32, Kamiminami, Hirano-ku Osaka 547-0003, Japan

S-13702HZ-CD-①

© 2000 Icom Inc.