



INSTRUCTION MANUAL

DSC CONTROLLER
DS-100

(#02)

Icom Inc.

FOREWORD

Thank you for purchasing this Icom product. The DS-100 (#02) DSC CONTROLLER is designed and built with Icom's superior technology and craftsmanship. With proper care this product should provide you with years of trouble-free operation.

IMPORTANT

READ ALL INSTRUCTIONS carefully and completely before using the controller.

SAVE THIS INSTRUCTION MANUAL—This instruction manual contains important operating instructions for the DS-100.

EXPLICIT DEFINITIONS

WORD	DEFINITION
⚠ WARNING	Personal injury, fire hazard or electric shock may occur.
CAUTION	Equipment damage may occur.
NOTE	If disregarded, inconvenience only. No risk of personal injury, fire or electric shock.

FEATURES

Class D DSC terminal

The DS-100 (#02) VHF DSC CONTROLLER is designed as a 'Class D DSC terminal unit' for the **IC-M401EURO** or **IC-M503** VHF MARINE TRANSCEIVERS.

DS-100 (#02) is not compatible with DS-100 (#01). The plug of the control cable is a different type.

Self ID indication

THE MMSI NUMBER SHOULD BE PROGRAMMED BY A DEALER PRIOR TO INSTALLATION.

The DS-100 (#02) does not function when there is no ID programmed. Therefore, the ID code should be checked in the Set-up menu.

Icom, Icom Inc. and the  logo are registered trademarks of Icom Incorporated (Japan) in the United States, the United Kingdom, Germany, France, Spain, Russia and/or other countries.

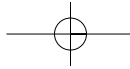

CAUTIONS

⚠ WARNING! NEVER connect the controller to an AC outlet. This may pose a fire hazard or result in an electric shock.

⚠ WARNING NEVER transmit a distress call when your vessel does not need immediate help. Distress calls can be used only in times of emergency.

NEVER connect the controller to a power source of more than 16 V DC. Such a connection will ruin the controller.

NEVER place the controller where normal operation of the ship may be hindered or where it could cause bodily injury.

AVOID using or placing the controller in direct sunlight or in areas with temperatures below -20°C (-4°F) or above $+60^{\circ}\text{C}$ ($+140^{\circ}\text{F}$).

KEEP the controller out of the reach of children.

KEEP the antenna cable and DC power cable as far away as possible from electrical pumps, generators and other electronic instruments to prevent instrument malfunctions.

KEEP the controller and microphone at least 1 meter away from your vessel's magnetic navigation compass.

DO NOT use chemical agents such as benzene or alcohol when cleaning, as they can damage the terminal unit surfaces.

CE CE Versions of the DS-100 which display the "CE" symbol on the serial number seal, comply with the essential requirements of the European Radio and Telecommunication Terminal Directive 1999/5/EC.



This warning symbol indicates that this equipment operates in non-harmonised frequency bands and/or may be subject to licensing conditions in the country of use. Be sure to check that you have the correct version of this radio, or the correct programming for this radio, to comply with national licensing requirements.

TABLE OF CONTENTS

FOREWORD	i	■ Address ID	18
IMPORTANT	i	■ Offset time	20
EXPLICIT DEFINITIONS	i	■ Brightness	20
FEATURES	i	■ Contrast	20
WARNING	i	■ MMSI check	20
CAUTIONS	ii	5 CONNECTIONS AND INSTALLATION	21–23
TABLE OF CONTENTS	iii	■ Connection diagram	21
1 PANEL DESCRIPTION	1–2	■ Rear panel description	22
■ Front panel	1	■ Supplied accessories	22
■ Function display	2	■ Mounting	23
2 CALL PROCEDURE	3–8	6 VHF MARINE CHANNEL LIST	24
■ Entry an MMSI	3	7 SPECIFICATIONS AND OPTIONS	25
■ Distress call/Simple operation	4	■ Specifications	25
■ Distress call/Regular operation	5	■ Options	25
■ Entry Position/Time	6	8 DIMENSIONS	26
■ Distress call to ships	7	9 MB-75 (OPTION)	27–28
■ Individual call	7	■ MB-75 FLUSH MOUNT KIT	27
■ Group call	8	10 TEMPLATE	29
■ All ships call	8	11 DOC	31
3 WHEN RECEIVING A DSC CALL	10–17		
■ When receive a distress call	10		
■ Received message	14		
4 SET-UP	18–20		
■ Select 'Set-up'	18		

PANEL DESCRIPTION

1

■ Front panel

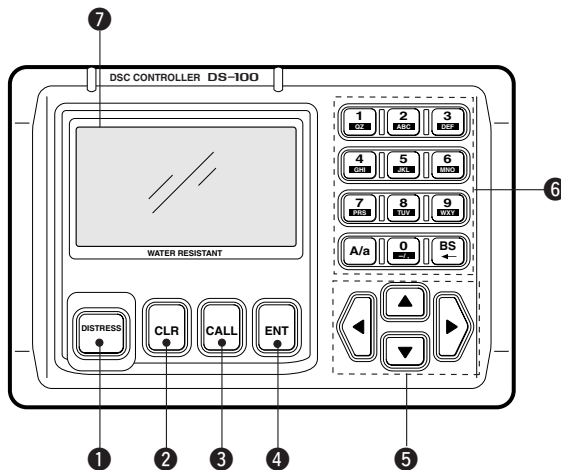

1 DISTRESS BUTTON

Push and hold for 5 sec. to make a distress call.

2 CLEAR SWITCH [CLR]

- Push this key to cancel Call repeat.
- Push this key to cancel the menu.

3 CALL SWITCH [CALL]

- Push this key to call up a subject menu screen.
- Push the key to return to the start screen.

4 ENTER [ENT]

- Enters the selected subject and advances the item to indicate the contents.
- Push this key to determine the data.

5 UP/DOWN/LEFT/RIGHT SWITCHES [▲]/[▼]/[◀]/[▶]

- Push [▲]/[▼] to select the menu contents in the selected item.
- Push [▲]/[▼] to adjust brightness and contrast.
- Push [◀]/[▶] to move the cursor position.

6 KEYPAD

- Input the corresponding number or letters when required.
- Other functions are as follows;
 - [A/a]—Push this key to toggle between capital letters, small letters or numerals. 'A; capital letter' or 'a; small letter' appears in the upper right of the display, depending on selection.
 - [BS]—Backspace key.

7 FUNCTION DISPLAY

During normal operation the display shows position and UTC (or Local) time when a GPS receiver is connected. This is updated each time new GPS data is received.

If no GPS receiver is connected, the position and UTC time must be set in advance.

1 PANEL DESCRIPTION

NOTE: If GPS data is interrupted for 30 sec. the “GPS” indication disappears. The terminal unit retains the most recent data in such cases.

■ Function display

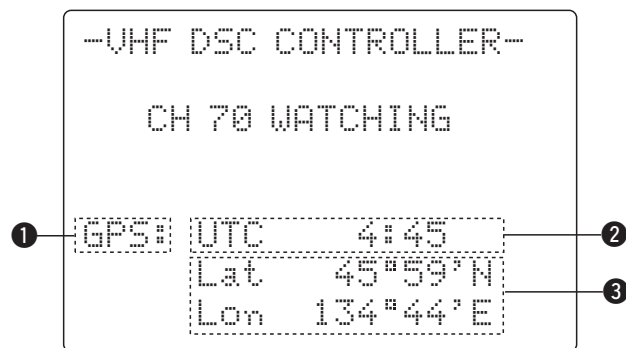

① GPS INDICATOR

- “GPS” appears while GPS receiver is connected.
- “GPS” disappears when no GPS receiver is connected.
- “MNL” appears when the time data and position data are input manually.

② TIME ZONE INDICATOR

- “Local” appears when the offset time data in the ‘Set-up’ menu is entered.
- “No time data” appears when no GPS receiver is connected and no time data is input manually.

③ POSITION INDICATOR

- Shows the GPS position data.
 - “??” may blink every 2 sec. instead of position data, when the GPS position data is invalid. In such a case, the last position data is held for up to 23.5 hours.
- Shows the manually input position data when no GPS receiver is connected. “MNL” appears instead of “GPS” at ①.
 - “??” may blink every 2 sec. instead of position data, 4 hours after the position data is input manually up until 23.5 hours have past.
- “No position data” appears when no GPS receiver is connected and no position data is input manually.

NOTE: When no key operation is made for more than 5 minutes, the function display contents returns to the opening menu message as shown at left, automatically.

CALL PROCEDURE

2

■ Entering an MMSI

An ID code of your ship must be entered before using the unit for the first time. Only 3 selectable subjects appear when your ID code has not been entered yet. No distress call can be transmitted in the above condition.

<Select a subject>

Entry position/time
Received calls
▶Set up

◆ Entering an MMSI

- ① Push [CALL], then push [▼] to select 'Set up'.
- ② Push [ENT], then push [▼] several times to select 'MMSI entry', then push [ENT] again.
- ③ Enter the 9 (nine) digit ID code.
- ④ Push [POWER] on the connected transceiver to turn the power OFF.
- ⑤ Push [POWER] to turn the power ON again. All operating items/functions can be selected and use from now on.

<Select a subject>

Brightness
Contrast
MMSI check
▶MMSI entry

<CLR Exit / ENT OK>

<Entry a MMSI >

ID: (9digit)

Turn power OFF once,
then turn it ON again

2 CALL PROCEDURE

■ Distress call/simple operation

A distress call should be transmitted if, in the opinion of the Master, the ship or a person is in distress and requires immediate assistance.

A distress call should include the ship's position and time. They are included automatically when a GPS receiver is connected. If no GPS is connected, input them, if possible.

NEVER: USE THE DISTRESS CALL WHEN YOUR SHIP IS NOT IN AN EMERGENCY. DISTRESS CALL CAN BE USED ONLY WHEN IMMEDIATE HELP IS NEEDED.

- ① Confirm any distress call is not being received.
- ② Lift up the switch cover. Push and hold the [DISTRESS] button for 5 sec. to transmit the distress call.
 - A DSC channel (Ch 70) is automatically selected and the distress call is transmitted.
 - If you have the time, select the nature of the distress and contents.
 - If no GPS is connected, your location and UTC time should be input.
- ③ After transmitting the call, the transceiver is set to the

<Push and hold
[DISTRESS] for 5 sec>

Nature of distress:
Undesignated
GPS : UTC 15:22
12°34'N
123°45'W

phone frequency (Ch 16) automatically.

- The controller is still waiting on Ch 70 for an acknowledgment call.
- ④ When receiving the acknowledgment, reply to the connected station via the transceiver's microphone as described on the page at right.

Distress alert
Completed

Now waiting for
acknowledgment

<CLR→Exit>

NOTE:

- Distress alert (simple operation) contains (default);
Kind of distress: Undesignated distress
Position data: According to the displayed information.
- GPS or manual input position data held for 23.5 hrs.
- Distress call repeats every 3.5–4.5 min., until receiving an 'acknowledgement'
- Beep (Pi,Pi) sounds with the max. volume every 1 sec.
- Push [DISTRESS] button to transmit a renewed distress call, if desired.
- Push [CLR] to cancel the 'Call repeat' mode.
The 'cancel acknowledgement' is automatically transmitted when the [CLR] key is pushed.

CALL PROCEDURE 2

■ Distress call/Regular operation

Transmit a distress call after selecting the 'Distress setting'.

NEVER: USE THE DISTRESS CALL WHEN YOUR SHIP IS NOT IN AN EMERGENCY. DISTRESS CALL CAN BE USED ONLY WHEN IMMEDIATE HELP IS NEEDED.

- ① Push [CALL], then push [▼] several times to select 'Distress setting'.
- ② Push [ENT] to select <Select a nature>. Push [▼] several times to select the desired nature, then push [ENT].
 - Push [CLR] to Exit the menu.
- ③ Confirm the location data, then push [ENT] to confirm the time data.
- ④ Confirm the UTC time, then push [ENT] to confirm the time data.
 - If no GPS is connected, your location and UTC time should be input.

<Select a subject>

Entry position/time
Individual call
Group call
All ships call
Received calls
▶Distress setting

- ⑤ Lift up the [DISTRESS] switch cover. Push and hold the button for 5 sec. to transmit the distress call.
 - A DSC channel (Ch 70) is automatically selected and the distress call is transmitted.
 - If no GPS is connected, your location and UTC time should be input.
- ⑥ After transmitting the call, the transceiver is set to the voice calling channel (Ch 16) automatically.
 - The controller is still waiting for an acknowledgment call on Ch 70.
- ⑦ When receiving the acknowledgment, reply to the connected station via the transceiver's microphone as described on page 8.

<Select a nature>

Undesignated
Fire, Explosion
Flooding
Collision
Grounding
Capsizing
▶Sinking
Disable adrift
Abandoning ship
Piracy attack
Man overboard
EPIRB emission

<Push and hold
[DISTRESS] for 5 sec>

Nature of distress:
Abandoning ship
GPS : UTC 15:22
12.34'N
123.45'W

2 CALL PROCEDURE

NOTE:

- 'nature of distress' will be valid for 10 min. until a distress call transmits. After 10 min. it reverts to an undesignated distress.
- Distress call repeats every 3.5–4.5 min., until receiving an 'acknowledgement'
- Beep (Pi,Pi) sounds with the max. volume every 1 sec. until acknowledgement is received.
- Push clear to cancel a distress call prior to receiving and an acknowledgement.

The 'cancel acknowledgement' is automatically transmitted when the [CLR] key is pushed.

■ Entry Position/Time

When no GPS receiver is connected, the 'Entry Position/Time' appears at the top of the subject menu.

- ① Push [CALL], then push [▼] to select 'Entry Position/Time'.
- ② Push [ENT], then enter the latitude data with the key pad.
- ③ Push [▲]/[▼] to select N; north latitude or S; south latitude, then push [ENT].
 - Push [◀]/[▶] to move the cursor then push [▲]/[▼] to correct the data
 - Push [CLR] to Exit the menu.
 - Push [A/a], the push [ENT] to enter 'Null data'.
- ④ Enter the longitude data with the key pad.
- ⑤ Push [▲]/[▼] to select E; east longitude or W; west longitude, then push [ENT].
 - Push [◀]/[▶] to move the cursor then push [▲]/[▼] to correct the data
 - Push [CLR] to Exit the menu.
 - Push [A/a], the push [ENT] to enter 'Null data'.

<Input a position>

Latitude

_____ ° 'N

Longitude

_____ ° 'E

<A/a Null data>

<CLR Exit / ENT OK>

<Input a Time>

UTC _____ :

<A/a Null data>

<CLR Exit / ENT OK>

CALL PROCEDURE 2

- ⑥ Push UTC time with the keypad.
- Push [◀]/[▶] to move the cursor then push [▲]/[▼] to correct the data
 - Push [CLR] to Exit the menu.
 - Push [A/a], then push [ENT] to enter 'Null data'.

■ Distress call to ships

General DSC calls may be used for communications after the Distress call, e.g. you want to change the operating mode, frequency, etc.

■ Individual call

◇ Individual call to the coast station

- ① Push [CALL], then push [▼] several times to select 'Individual call' then push [ENT].
- ② Push [▼] several times to select the coast station ID address. Then push [ENT].
(See page 18 for adding an address.)
- ③ Select the coast station ID.
- ③ Push [CALL] and [ENT] simultaneously to transmit an Individual call.
 - Push [CLR] to stop the call.
- ④ 'RCV Individual call—From: Coast stn', appears on the screen.

- ⑤ Push [ENT] to transfer the instructed traffic channel* to the transceiver.

* Traffic channel is determined by the coast station automatically.

◇ Individual call to other ships

- ① Push [CALL], then push [▼] several times to select 'Individual call' then push [ENT].
- ② Select 'manual entry' to enter 9 digit ID or push [▼] to select the desired ID address. Then push [ENT].
 - 'Select a traffic CH' screen appears.
- ③ Push [▲]/[▼] to select your desired traffic channel from the list. Then push [ENT].
- ④ Push [CALL] and [ENT] simultaneously to transmit an Individual call.
 - Push [CLR] to stop the call.

```
<Select address ID>

▶Manual entry
DS-100 SN10
DS100 SN2
DS100 SN3

<CLR Exit / ENT OK>
```

```
<Input address ID>

ID: (9digit)
_____

<CLR Exit / ENT OK>
```

2 CALL PROCEDURE

■ Group call

- ① Push [CALL], then push [▼] one or more times to select 'Group call', then push [ENT].
- ② Select 'manual entry' to enter 8 digit ID or push [▼] to select the desired ID address. Then push [ENT].
 - 'Select a traffic CH' screen appears.
- ③ Push [▲]/[▼] to select your desired traffic channel from the list. Then push [ENT].
- ④ Push [CALL] and [ENT] simultaneously to transmit an Individual call.
 - Push [CLR] to stop the call.

<Select a group>

►Manual entry
ICOM

<CLR Exit / ENT OK>

<Input an address>

ID: (8digit)
0 _____

<CLR Exit / ENT OK>

■ All ships call

- ① Push [CALL], then push [▼] one or more times to select 'All ships call', then push [ENT].
- ② Select the desired category, then push [ENT].
- ③ To select desired traffic channel push [BS] twice and enter channel number.*
- ④ Push [CALL] and [ENT] simultaneously to transmit an All ships call.
 - Push [CLR] to stop the call.

<Select a category>

Safety
►Urgency

<CLR Exit / ENT OK>

* Traffic channel automatically defaults to channel 16.

CALL PROCEDURE 2

◇ When no acknowledgement is received

When no acknowledgement is received the unit will beep every one second. In this case, the controller automatically transmits the distress call again every 3.5 to 4.5 minutes.

- A distress relay call may be received after several minutes from another ship if acknowledgement cannot be received from a coast station directly.

CAUTION: DO NOT push [CLR] while waiting for an acknowledgement, otherwise the distress call repeat will be cancelled, and a distress acknowledgement is automatically transmitted with your own MMSI.
Use the [CLR] key only when you want to cancel repeated transmission.

◇ After receiving an acknowledgement call

The following should be commenced with your voice transmission after receiving a distress acknowledgement from a coast station (or another ship).

- “MAY DAY”
- “This is(your ship name)”
- The 9-digit identity AND the call sign (or other identification of the ship).
- The ship’s position if the DSC distress does not include it.
- The nature of the distress and assistance required.
- Any other information which might facilitate the rescue.



3

WHEN RECEIVING A DSC CALL

■ When receiving a Distress call

When receiving a distress call, an alarm (PI-po) sounds with max. AF level continuously. And at the same time, the transceiver's (such as IC-M401EURO or IC-M503) operating channel changes to CH 16 automatically.

-RCV Distress call-

Distress ID:

23456789

Distress time & pos

Time: UTC 12:34

Pos.: Lat 12°34'N

Lon 123°45'W

- Push [CLR] to cancel the alarm.
- Monitor the communication between the calling ship and a coast station. When no communication is made, contact the ship using voice transmission on CH 16.

WHEN RECEIVING A DSC CALL 3

◆ When receiving an individual call

When receiving an individual call, an alarm (Pi-pi) sounds.

- Push [ENT], then the operating channel changes to the designated channel.
- Push [CLR] to record the received information, then the screen goes back to default.
- The calling station transmits via voice on the designated channel.

-RCV Individual call-

From: JOHN

<CLR→Exit/ ENT→OK>

• When the individual ACK function is available

When the individual acknowledgement function is available on your controller, push [ENT] to turn to the <Select to comply> screen.

- Select 'Able to comply' or 'Unable to comply'.
- Emergency alarm (or continuous beeps depending on the category) sounds until pushing [CLR].

<Select to comply>

▶Able to comply
Unable to comply

<CLR→Exit/ ENT→OK>

3 WHEN RECEIVING A DSC CALL

◇ When receiving an All ships call

- When receiving a Routine or Safety all ships call, an alarm (Pi-pi) sounds.
- When you receive a distress or Urgency all ships call, an alarm (Pi-po) sounds with max. AF level continuously.
 - Push [CLR] to cancel the alarm.
 - Push [ENT], then the operating channel changes to the received traffic channel automatically.
 - Push [CLR] to record the received information, then the screen goes back to default.

–RCV All ships call–

From: 23456789
Category: Routine

<CLR→Exit/ ENT→OK>

You must monitor the traffic frequency until you can judge from the call that your action has been effective and/or assistance is unnecessary.

◇ When receiving a Position request

When receiving a Position request call, an alarm (Pi-pi) sounds.

- Push [ENT] to transmit your own ships longitude and latitude information.
- Push [CLR] to record the received information, then the screen goes back to default.

–RCV Pos request–

From: JOHN

To reply, push ENT

<CLR→Exit/ ENT→OK>

◇ When receiving a Position reply

When receiving a Position reply, an alarm (Pi-pi) sounds.

- Push [CLR] to record the received information, then the screen goes back to default.

–RCV Pos reply–

From: Beck

Pos.: Lat 12°34'N
Lon 123°45'W

<CLR→Exit>

WHEN RECEIVING A DSC CALL 3

◇ When receiving a Distress ACK

When receiving a distress acknowledgement, an alarm (Pi-po) sounds with max. AF level continuously. And at the same time, the transceiver's (IC-M503/M401EURO) operating channel changes to CH 16 automatically.

- Push [CLR] to cancel the alarm.
- You must monitor CH 16 until you can judge from the call that your assistance is unnecessary.

—RCV Distress ACK—

From: Tokyo guard
Distress ID:
Mr.Bean

<CLR→Exit/ ENT→OK>

◇ When receiving a group call

When receiving a Group call, an alarm (Pi-pi) sounds.

- Push [ENT], then the operating channel changes to the designated channel.
- Push [CLR] to record the received information, then the screen goes back to default.
- The calling station transmits via voice on the designated channel.

—RCV Group call—

From: DS-100 SN3
Group:Icom Inc

<CLR→Exit/ ENT→OK>

◇ When receiving a Distress Relay ACK

When receiving a Distress Relay acknowledgement, an alarm (Pi-po) sounds with max. AF level continuously. And at the same time, the transceiver's (IC-M503/M401EURO) operating channel changes to CH 16 automatically.

- Push [CLR] to cancel the alarm.
- You must monitor CH 16 until you can judge from the call that your assistance is unnecessary.

—RCV Distress RLY ACK—

From: Tokyo guard
Distress ID:
987654321

<CLR→Exit/ ENT→OK>

3 WHEN RECEIVING A DSC CALL

■ Received message (RCV MSG)

When receiving a DSC call, the received format is specified and its contents are memorized into the received message (RCV MSG) memory. Distress calls (including other calls with distress category) are stored separately from other calls.

Up to 20 distress calls can be memorized and up to 20 other categories of calls can be memorized. However, the distress calls are saved until being erased, while other calls are erased when the power is turned OFF.

<Select a subject>

Entry Position/Time
Individual call
Group call
All ships call
▶Received calls
Distress setting

◇ Distress message

- ① Push [CALL], then push [▼] one or more times to select 'Received calls', then push [ENT].
- ② Select a 'Distress message', then push [ENT].
- ③ Select a desired message, then push [ENT].
 - Push [▲] or [▼] to scroll the message.
 - Push [A/a], then push [1] to clear the message.

NOTE: The message number that has not been read yet blinks, e.g. ✨.

<Select a message>

▶Distress message
Other message

<CLR Exit / ENT OK>

<Select a message>

▶1:Distress 12:21
2:Distress 11:21
❄3:Distress 10:21
4:Distress 09:21

<CLR Exit / ENT OK>

<Message contents>

Distress ID:
2345678
Piracy attack
Distress time & Pos
Time: UTC 12:34
Pos.: Lat 12°34'N
Lon 123°45'W

<A/a Data clear>

WHEN RECEIVING A DSC CALL 3

◆ Other messages

• Individual call

- ① Push [CALL], then push [▼] several times to select 'Received calls', then push [ENT].
- ② Select 'Other message', then push [ENT].
- ③ Select 'Individual call', then push [ENT].
 - Push [▲] or [▼] to scroll the message.
 - Push [A/a] to clear the message.

<Select a message>

```
1:Individual ACK
▶2:Individual call
3:Group call
4:All ships call
5:Distress
6:Distress relay
7:Distress RLY ACK
8:Distress ACK
```

<CLR Exit / ENT OK>

<Message contents>

```
Routine to Individual
From: DS-100 SN3
F3E/G3E simplex
CH88
No information
```

<A/a Data clear>

• Group call

- ① Push [CALL], then push [▼] several times to select 'Received calls', then push [ENT].
- ② Select 'Other message', then push [ENT].
- ③ Select 'Group call', then push [ENT].
 - Push [▲] or [▼] to scroll the message.
 - Push [A/a] to clear the message.

<Select a message>

```
1:Individual ACK
2:Individual call
▶3:Group call
4:All ships call
5:Distress
6:Distress relay
7:Distress RLY ACK
8:Distress ACK
```

<CLR Exit / ENT OK>

<Message contents>

```
Routine to group
From: Phil Collins
F3E/G3E simplex
CH78
No information
```

3 WHEN RECEIVING A DSC CALL

• All ships

- ① Push [CALL], then push [▼] several times to select 'Received calls', then push [ENT].
- ② Select 'Other message', then push [ENT].
- ③ Select 'All ships call', then push [ENT].
 - Push [▲] or [▼] to scroll the message.
 - Push [A/a] to clear the message.

```
<Message contents>

Urgency to All ships
From: DS-100 SN3
F3E/G3E simplex
CH 14

<A/a Data clear>
```

• Distress

- ① Push [CALL], then push [▼] several times to select 'Received calls', then push [ENT].
- ② Select 'Other message', then push [ENT].
- ③ Select 'Distress', then push [ENT].
 - Push [▲] or [▼] to scroll the message.
 - Push [A/a] to clear the message.

```
<Message contents>

Routine to group
From: Phil Collins
F3E/G3E Simplex
CH88
No Information

<A/a Data clear>
```

• Distress relay

- ① Push [CALL], then push [▼] several times to select 'Received calls', then push [ENT].
- ② Select 'Other message', then push [ENT].
- ③ Select 'Distress relay', then push [ENT].
 - Push [▲] or [▼] to scroll the message.
 - Push [A/a] to clear the message.

```
<Message contents>

Distress relay
From: Phil Collins
Distress ID:
  2345678
To all ships
Fire,Explosion
Distress Time & Pos
Time: UTC 12:34
Pos.: Lat 12°34'N
      Lon 123°45'W

<A/a Data clear>
```

WHEN RECEIVING A DSC CALL 3

• Distress relay acknowledgement

- ① Push [CALL], then push [▼] several times to select 'Received calls', then push [ENT].
- ② Select 'Other message', then push [ENT].
- ③ Select 'Distress RLY ACK', then push [ENT].
 - Push [▲] or [▼] to scroll the message.
 - Push [A/a] to clear the message.

<Select a message>

```
1:Individual ACK
2:Individual call
3:Group call
4:All ships call
5:Distress
6:Distress relay
▶7:Distress RLYACK
8:Distress ACK
```

<CLR Exit / ENT OK>

<Message contents>

```
Distress RLY ACK
From: Mr.Comfort
Distress ID:
  Mrs.John
Fire,Explosion
Distress Time & Pos
Time: UTC 12:34
Pos.: Lat 12°34'N
      Lon 123°45'W
```

<A/a Data clear>

• Distress acknowledgement

- ① Push [CALL], then push [▼] several times to select 'Received calls', then push [ENT].
- ② Select 'Other message', then push [ENT].
- ③ Select 'Distress ACK', then push [ENT].
 - Push [▲] or [▼] to scroll the message.
 - Push [A/a] to clear the message.

<Select a message>

```
1:Individual ACK
2:Individual call
3:Group call
4:All ships call
5:Distress
6:Distress relay
7:Distress RLYACK
▶8:Distress ACK
```

<CLR Exit / ENT OK>

<Message contents>

```
Distress ACK
From: Mr.Fortune
Distress ID:
  Mrs.John
Fire,Explosion
Distress Time & Pos
Time: UTC 12:34
Pos.: Lat 12°34'N
      Lon 123°45'W
```

<A/a Data clear>

4

SET-UP

■ Select 'Set-up'

The following setting/operations are available in 'Set-up' menu.

- Address ID
- Offset time
- Brightness
- Contrast
- MMSI check

- ① Push [CALL], then push [▼] several times to select 'Set-up', then push [ENT].
 - 'Set-up' menu appears on the screen.
- ② Push [CLR] to exit the Set-up menu.

<Select a subject>

Individual ACK
Group call
All ships call
Received calls
Distress setting
▶Set-up

<Select a subject>

▶Address ID
Offset time
Brightness
Contrast
MMSI CHECK

<CLR→Exit / ENT→OK>

■ Address ID

A total of 70 address ID's can be programmed as "Address ID" (for ships and coast stations) and "Group ID" (for group station).

• Adding an address ID

- ① Push [▲]/[▼] several times to select 'Add an address ID', then push [ENT].
- ② Push the numeral keys to input an address ID code, then push [ENT].
 - When a wrong number is input, push [CLR], then enter the number again.
- ③ Enter the desired name for the ID code, then push [ENT].
 - Push [A/a] several times to toggle capital letters, small letters and numerals.
 - Push the corresponding key one or more times to input the desired character.
 - Push [BS] to erase the character.
 - Push [◀] to reverse the cursor position; [▶] to forward the cursor position.
- ④ Push [CLR] to exit the screen.

<Select a subject>

▶Add an address ID
Delete address ID
Add a group ID
Delete a group ID

<CLR→Exit / ENT→OK>

<Add an address ID>a*

ID: (9digit)

Name: (15characters)

<CLR→Exit / ENT→OK>

SET-UP 4

• Delete address ID

- ① Push [▼] to select 'Delete address ID', then push [ENT].
- ② Push [▲]/[▼] several times to select a desired address ID that you want to delete, then push [ENT].
 - Address ID and name is displayed on the screen.
- ③ Push [ENT] to delete the address ID.
 - Push [CLR] to exit the screen.
- ④ Push [CLR] to exit the menu.

```
<Delete address ID>
```

```
▶DS-100 SN10
DS-100 SN2
DS-100 SN3
DS-100 SN4
```

```
<CLR→Exit/ENT→OK>
```

```
<Delete this ID>
```

```
ID: (9digit)
2673500100
Name: (15characters)
DS-100 SN10
```

```
<CLR→Exit / ENT→OK>
```

• Add a group ID

- ① Push [▲]/[▼] several times to select 'Add a group ID', then push [ENT].
- ② Push numeral keys to input an address ID code, then push [ENT].
 - When a wrong number is input, push [CLR], then enter the number again.
- ③ Enter the desired name for the ID code, then push [ENT].
 - Push [A/a] several times to toggle capital letters, small letters and numerals.
 - Push the corresponding key one or more times to input the desired character.
 - Push [BS] to erase the character.
 - Push [◀] to reverse the cursor position; [▶] or forward the cursor position.
- ④ Push [CLR] to exit the screen.

```
<Add a group ID> a*
```

```
ID: (8digit)
0
Name: (15characters)
```

```
<CLR→Exit / ENT→OK>
```

• Delete a group ID

- ① Push [▼] to select 'Delete a group ID', then push [ENT].
- ② Push [▲]/[▼] several times to select a desired address ID that you want to delete, then push [ENT].
 - Address ID and name is displayed on the screen.
- ③ Push [ENT] to delete the address ID.
 - Push [CLR] to exit the screen.
- ④ Push [CLR] to exit the menu.

4 SET-UP

■ Offset time

Local time can be used when the GPS position data is valid and offset time is input.

- ① Push [CALL], then push [▼] one or more times to select 'Set-up', then push [ENT].
- ② Select 'Offset time', then push [ENT].
- ③ Push "0; -" or "1; space", then input the time differences.
- ④ Push [ENT] to determine the time or push [CLR] to exit the Set-up menu.

```
<Offset time>
-09:30
<CLR→Exit / ENT→OK>
```

■ Brightness

• Adjusting the brightness

- ① Push [CALL], then push [▼] one or more times to select 'Set-up', then push [ENT].
- ② Select 'Brightness', then push [ENT].
- ③ Push [▲] or [▼] one or more times (or numeral keys instead) to adjust the brightness.
 - Brightness level indication; 1 (dark) to 8 (bright)
- ④ Push [ENT] to determine the brightness or push [CLR] to exit the Set-up menu.

■ Contrast

• Adjusting the contrast

- ① Push [CALL], then push [▼] one or more times to select 'Set-up', then push [ENT].
- ② Select 'Contrast', then push [ENT].
- ③ Push [▲] or [▼] one or more times (or numeral keys instead) to adjust the contrast.
 - Contrast level indication; 1 (low) to 8 (high)
- ④ Push [ENT] to determine the brightness or push [CLR] to exit the Set-up menu.

■ MMSI check

Your ID code can be displayed via the set-up menu.

• Check your ID

- ① Push [CALL], then push [▼] one or more times to select 'Set-up', then push [ENT].
- ② Select 'MMSI check', then push [ENT].
- ③ Your ID code shows on the display.
- ④ Push [CLR] to exit the Set-up menu.

```
<MMSI check>
267350012
<CLR Exit>
```

CONNECTIONS AND INSTALLATION

■ Connection diagram (Connection example with IC-M503)

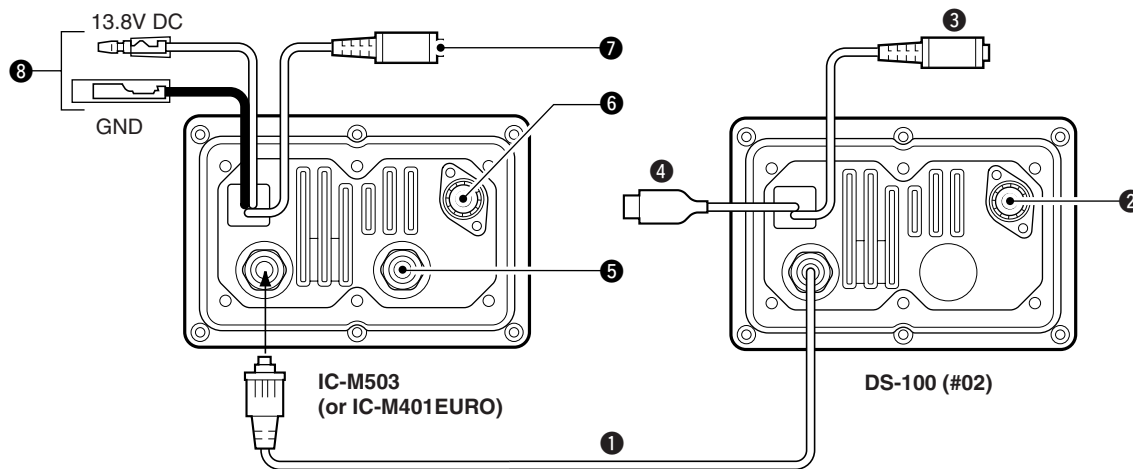

NOTE: Binding the GPS cable, GPS connector, clone receptacle, antenna connector with water-resistant tape, increases the waterproofing of the controller.

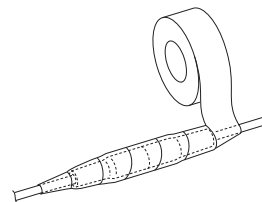

5 CONNECTION AND INSTALLATION

■ Rear panel description

① CONNECTION CABLE

Connects to the IC-M503 (or IC-M401EURO) rear DSC controller receptacle.

② RECEIVE ANTENNA CONNECTOR

Connects a marine VHF receiving antenna with a PL-259 plug for emergency frequency signal receiving.

- Receiving frequency : 156.525 MHz
- Keep the emergency frequency signal receiving antenna away from the marine VHF antenna to avoid interference from the emitted RF signal.

③ CLONE RECEPTACLE

For dealer use only.

④ GPS RECEIVER CONNECTOR

Connects a GPS receiver (NMEA0183 ver.2.0) for sending position data without manual input.

⑤ EXTERNAL MICROPHONE CONNECTOR (IC-M503)*

Connects to the optional **HM-134** REMOTE-CONTROL MICROPHONE.

- Intercom function is available.

CAUTION: NEVER connect another microphone such as the HM-127, etc. It may cause damage to the transceiver.

⑥ ANTENNA CONNECTOR (IC-M503)*

Connects a marine VHF antenna with a PL-259 connector to the transceiver.

⑦ EXTERNAL SPEAKER RECEPTACLE (IC-M503)*

Connects to an external speaker.

⑧ DC POWER CONNECTOR (IC-M503)*

Connects the DC power cable supplied with IC-M503 (or IC-M401EURO), from this connector to an external 12 V DC power source.

*Refer to the IC-M503 (or IC-M401EURO) instruction manual.

■ Supplied accessories

① Knob bolt (2040 knob bolt)	2
② Mounting bracket (2345 Mobile bracket)	1
③ Spring washers (M 5)	2
④ Self-tapping screws (A05 x 20).....	2
⑤ Flat washers (M 5).....	2
⑥ Label (2349 CAUTION seal-R).....	1

CONNECTION AND INSTALLATION 5

■ Mounting

The universal mounting bracket supplied with your controller allows dashboard or overhead mounting. Please read the following instructions carefully.

- Mount the controller securely with bolts and nuts or it may come loose as a result of wave shocks or vibration.
- Mount the controller so that the face of the controller is at 90 degrees to your line of sight when operating it.

CAUTION!

KEEP the controller at least 1 m away from your ship's magnetic navigation compass.

CHECK the installation angle; the function display may not be easy-to-read at some angles.

• OVERHEAD MOUNTING

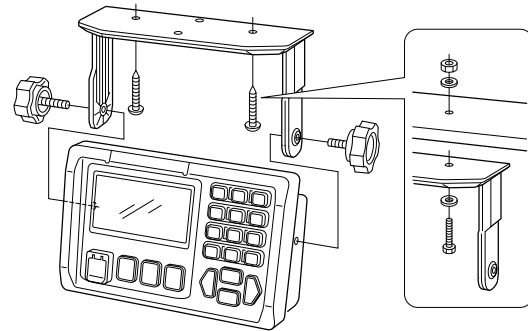

• DASHBOARD MOUNTING (with optional MB-75):

For mounting the DS-100 to a dashboard panel.

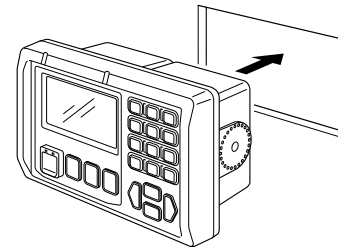

6

VHF MARINE CHANNEL LIST

◇ International channels

CH	Frequency (MHz)		CH	Frequency (MHz)		CH	Frequency (MHz)		CH	Frequency (MHz)		CH	Frequency (MHz)		CH	Frequency (MHz)	
	Transmit	Receive		Transmit	Receive		Transmit	Receive		Transmit	Receive		Transmit	Receive		Transmit	Receive
01	156.050	160.650	11	156.550	156.550	21	157.050	161.650	62	156.125	160.725	72	156.625	156.625	82	157.125	161.725
02	156.100	160.700	12	156.600	156.600	22	157.100	161.700	63	156.175	160.775	73	156.675	156.675	83	157.175	161.775
03	156.150	160.750	13	156.650	156.650	23	157.150	161.750	64	156.225	160.825	74	156.725	156.725	84	157.225	161.825
04	156.200	160.800	14	156.700	156.700	24	157.200	161.800	65	156.275	160.875	75	156.775	156.775	85	157.275	161.875
05	156.250	160.850	15	156.750	156.750	25	157.250	161.850	66	156.325	160.925	76	156.825	156.825	86	157.325	161.925
06	156.300	156.300	16	156.800	156.800	26	157.300	161.900	67	156.375	156.375	77	156.875	156.875	87	157.375	157.375
07	156.350	160.950	17	156.850	156.850	27	157.350	161.950	68	156.425	156.425	78	156.925	161.525	88	157.425	157.425
08	156.400	156.400	18	156.900	161.500	28	157.400	162.000	69	156.475	156.475	79	156.975	161.575			
09	156.450	156.450	19	156.950	161.550	60	156.025	160.625	70	156.525	156.525	80	157.025	161.625			
10	156.500	156.500	20	157.000	161.600	61	156.075	160.675	71	156.575	156.575	81	157.075	161.675			

SPECIFICATIONS AND OPTIONS

7

■ Specifications

General

- Operating frequency : 156.525 MHz
- Mode : 16K0G2B
- Operating temperature range : -20°C to +60°C; -4°F to +140°F
- Dimensions : 165(W) × 110(H) × 80(D) mm
(projections not included) 6.5 (W) × 4.33(H) × 3.15(D) in
- Weight : 1 Kg; 2.2 lb
- Receive system : Double-conversion
superheterodyne
- Intermediate frequencies : 1st 21.70 MHz
2nd 450 kHz
- Sensitivity : -10 dBμ typ.
- Intermodulation rejection ratio : More than 68 dB
- Adjacent channel selectivity : More than 73 dB
- Spurious response rejection ratio : More than 73 dB

*Measurement methods according to EN 301 025

■ Options

MB-75 FLUSH MOUNT KIT

For mounting the DS-100 to a panel.

8

DIMENSIONS

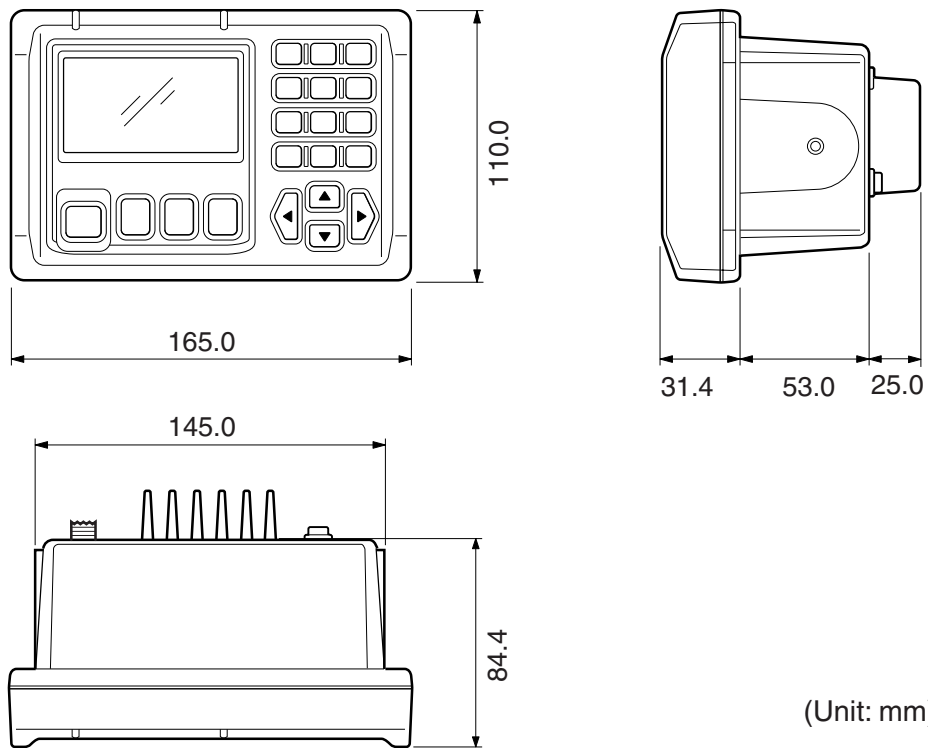

MB-75 (OPTION)

9

■ MB-75 FLUSH MOUNT KIT

The MB-75 is used to mount the DS-100 DSC CONTROLLER flush to a flat surface such as an instrument panel.

• Supplied accessories

Clamps 1 set

• Instructions

- ① Using the template (p. 29), carefully cut a hole into the instrument panel (or wherever you plan to mount the controller) and slide the controller through the hole on the rear panel.

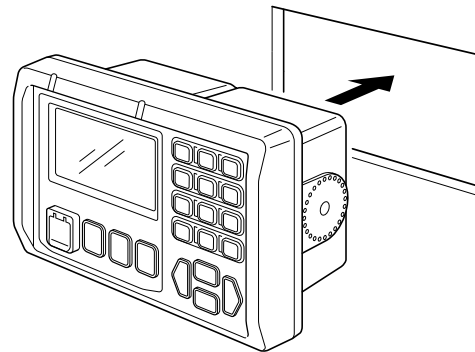
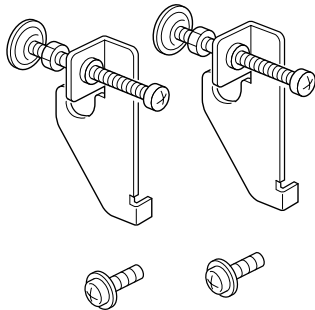

- ② Attach the 2 supplied bolts on either side of the DS-100 (See next page.)

9 MB-75

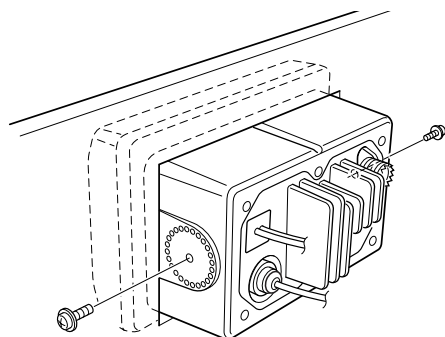

- ③ Attach the clamps on either side of the DS-100 as shown below.
- Make sure that the clamps align parallel to the DS-100's body.

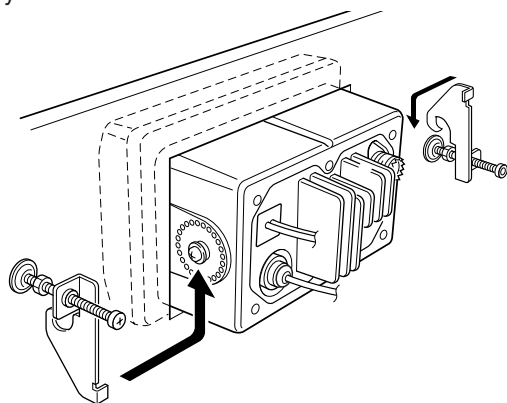

- ④ Tighten the end bolts on the clamps (rotate clockwise) so that the clamps press firmly against the inside of the instrument control panel.

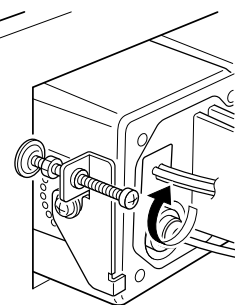

- ⑤ Tighten the locking nuts (rotate counterclockwise) so that the DS-100 is securely mounted in position as below.

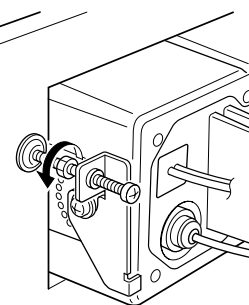

- ⑥ Connect the antenna and control cable, then return the instrument control panel to its original place.

TEMPLATE 10



• Cut on the inside of the line.

149 ($5\frac{7}{8}$)

4-R11 ($\frac{7}{16}$)

92 ($3\frac{5}{8}$)

Cut here

Unit: mm (inch)

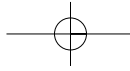
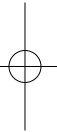
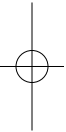
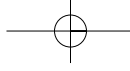

DOC 11



We Icom Inc. Japan
1-1-32 Kamiminami, Hirano-ku
Osaka 547-0003 Japan

Declare on our sole responsibility that this equipment complies the essential requirements of the Radio and Telecommunications Terminal Equipment Directive, 1999/5/EC, and that any applicable Essential Test Suite measurements have been performed.

Kind of equipment: DSC CONTROLLER

Type-designation: DS-100

Version (where applicable):

This compliance is based on conformity with the following harmonised standards, specifications or documents:

- | | |
|-------------------|------------------|
| i) EN 301 025-1 | V1.1.2 (2000-08) |
| ii) EN 301 025-2 | V1.1.1 (2000-08) |
| iii) EN 301 025-3 | (2001-05) |
| iv) EN 60945 | 1997 |
| v) EN 60950 | 1992 |

DECLARATION OF CONFORMITY

C E0560 

Düsseldorf 31st May 2001
Place and date of issue

Icom (Europe) GmbH
Himmelgeisterstraße 100
D-40225 Düsseldorf

Authorized representative name

T. Maebayashi
General Manager

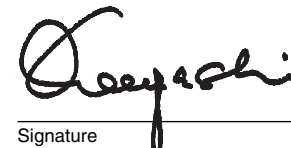

Signature

Icom Inc.

Count on us!

< Intended Country of Use >

- | | | |
|---|---|---|
| <input checked="" type="checkbox"/> GER | <input checked="" type="checkbox"/> NED | <input checked="" type="checkbox"/> ITA |
| <input checked="" type="checkbox"/> AUT | <input checked="" type="checkbox"/> BEL | <input checked="" type="checkbox"/> GRE |
| <input checked="" type="checkbox"/> GBR | <input checked="" type="checkbox"/> LUX | <input checked="" type="checkbox"/> SWE |
| <input checked="" type="checkbox"/> IRL | <input checked="" type="checkbox"/> ESP | <input checked="" type="checkbox"/> DEN |
| <input checked="" type="checkbox"/> FRA | <input checked="" type="checkbox"/> POR | <input checked="" type="checkbox"/> FIN |
| <input type="checkbox"/> SUI | | |

#02

A-6066H-1EU-②
Printed in Japan
© 2001 Icom Inc.

Icom Inc.

1-1-32 Kamiminami, Hirano-ku, Osaka 547-0003 Japan

offered by Busse-Yachtshop.com